

TECHNICAL MANUAL

**MAINTENANCE INSTRUCTIONS
ORGANIZATIONAL,
DIRECT SUPPORT AND GENERAL SUPPORT
(INCLUDING REPAIR PARTS
AND SPECIAL TOOLS LIST)**

**DISTRIBUTION BOX
J-3986/ALQ-151(V)**

DAAK20-80-C-0521

**Tracor Aerospace Austin, Inc.
DAAK21-84-C-0099**

**This publication is not available through AG Publications Center,
Requisition through Commander, US Army Electronics Materiel
Readiness Activity, Vint Hill Farms Station, Warrenton, Virginia 22186-
5141.**

HEADQUARTERS, DEPARTMENT OF THE ARMY

5 OCTOBER 1988

WARNING

High voltage is used in the operation of this equipment. Avoid contacting high-voltage connections when installing or repairing this equipment. Injury or death may result if personnel fail to observe safety precautions.

WARNING

Adequate ventilation should be provided while using trichlorotrifluoroethane. Prolonged breathing of vapor should be avoided. The solvent should not be used near heat or open flame; the products of decomposition are toxic and irritating. Since trichlorotrifluoroethane dissolves natural oils, prolonged contact with skin should be avoided. When necessary, use gloves that the solvent cannot penetrate. If the solvent is taken internally, consult a physician immediately.

**MAINTENANCE INSTRUCTIONS
 ORGANIZATIONAL, DIRECT SUPPORT AND
 GENERAL SUPPORT
 FOR
 DISTRIBUTION BOX
 J-3986/ALQ-151(V)**

REPORTING OF ERRORS

You can improve this manual by recommending improvements using DA Form 2028-2 located in the back of the manual. Simply tear out the self-addressed form, fill it out as shown on the sample, fold it where shown, and drop it in the mail.

If there are no blank DA Forms 2028-2 in the back of your manual, use the standard DA Form 2028 (Recommended Changes to Publications and Blank Forms) and forward to the Commander, U.S. Army Electronic Materiel Readiness Activity, Vint Hill Farms Station, Warrenton, Virginia 22186, Attn: SELEM-ME-E.

In either case a reply will be furnished directly to you.

TABLE OF CONTENTS

			Paragraph	Page
CHAPTER	1.	INTRODUCTION		
SECTION	I.	General		
		Scope	1-1	1-1
		Maintenance Forms and Records.....	1-2	1-1
		Destruction of Army Materiel to Prevent Enemy Use.....	1-3	1-1
		Administrative Storage.....	1-4	1-1
		Reporting of Errors.....	1-5	1-1
		Reporting Equipment Improvement Recommendations (EIR).....	1-6	1-1
SECTION	II.	Description and Data		
		Description.....	1-7	1-3
		Tabulated Data.	1-8	1-3
CHAPTER	2.	ORGANIZATIONAL MAINTENANCE INSTRUCTIONS		
		Scope	2-1	2-1
CHAPTER	3.	FUNCTIONING OF EQUIPMENT		
SECTION	I.	General		
		Scope	3-1	3-1

TABLE OF CONTENTS-Continued

			Paragraph	Page
		Organization	3-2	3-1
SECTION	II.	Functional Description		
		Power Distribution Box	3-3	3-1
CHAPTER	4.	DIRECT SUPPORT MAINTENANCE INSTRUCTIONS		
SECTION	I.	General		
		Scope	4-1	4-1
CHAPTER	5.	GENERAL SUPPORT MAINTENANCE INSTRUCTIONS		
SECTION	I.	General		
		Scope	5-1	5-1
		Organization	5-2	5-1
		Measurements and Data	5-3	5-1
SECTION	II.	Tools and Equipment		
		General	5-4	5-4
		Tools and Equipment Required	5-5	5-4
SECTION	III.	Troubleshooting		
		General	5-6	5-5
		Power Distribution Box Procedure	5-7	5-5
SECTION	IV.	Maintenance of Power Distribution Box		
		General	5-8	5-15
		Maintenance Procedures	5-9	5-15
		Removal Procedures	5-10	5-19
		Replacement Procedures	5-11	5-20
		Repair Procedures	5-12	5-22
SECTION	V.	General Support Test Procedure		
		General	5-13	5-39
		Test	5-14	5-39
APPENDIX	A.	REFERENCES		
		Scope	A-1	A-1
		Technical Manuals	A-2	A-1
		Supply Bulletins	A-3	A-2
		Common Table of Allowances	A-4	A-2
		Pamphlets.....	A-5	A-2
		Army Regulations	A-6	A-2
		Forms	A-7	A-3
APPENDIX	B.	MAINTENANCE ALLOCATION CHART		
SECTION	I.	Introduction		
		General	B-1	B-1
		Maintenance Functions	B-2	B-1
		Column Entries Used In the MAC	B-3	B-2
		Column Entries Used In Tool and Test	B-4	B-3
		Equipment Requirements (Section III)		
		Explanation of Columns Used In	B-5	B-4
		Section IV.		
SECTION	II.	Maintenance Allocation Chart for		
		Distribution Box J-3986/ALQ-151(V)		
SECTION	III.	Tool and Test Equipment Requirements		
		for Distribution Box J-3986/ALQ-151(V)		

TABLE OF CONTENTS-Continued

		Paragraph	Page
APPENDIX	C.	REPAIR PARTS AND SPECIAL TOOLS LIST	
		Scope	C-1 C-3
		General	C-2 C-3
		Explanation of Columns	C-3 C-3
		Special Information	C-4 C-8
		How to Locate Repair Parts.....	C-5 C-8
		Abbreviations	C-6 C-9
APPENDIX SECTION	D.	EXPENDABLE SUPPLIES AND MATERIALS LIST	
	I.	Introduction	
		Scope	D-1 D-1
		Explanation of Columns	D-2 D-1
SECTION	II.	Expendable Supplies and Materials List	
APPENDIX	E.	ILLUSTRATED LIST OF MANUFACTURED ITEMS	
		Introduction	E-1 E-1
		Manufactured Items Part Number Index	E-2 E-1
GLOSSARY INDEX			

LIST OF ILLUSTRATIONS

Figure	Title	Page
1-1	Distribution Box J-3986/ALQ-151(V).....	1-2
3-1	Control Circuits, Simplified Schematic Diagram	3-2
3-2	DC Power Distribution, Simplified Schematic Diagram	3-4
3-3	AC Power Distribution, Simplified Schematic Diagram	3-6
5-1	DC Input Test Setup	5-12
5-2	AC Input Test Setup	5-13
5-3	Power Distribution Box Component Locations	5-16
5-4	Filter FL-1 through FL-5 Replacement	5-17
5-5	Connecting Link Replacement	5-18
5-6	Circuit Breaker Replacement	5-23
5-7	Threaded Insert Removal and Replacement Tools.....	5-38
C-1	Distribution Box J-3986/ALQ-151(V)	C-10
E-1	Test Cable W1	E-2
E-2	Test Cable W2	E-3
E-3	Connector Assy P8	E-4
E-4	Connector Assy P2	E-4
FO-1	Power Distribution Box Schematic Diagram	
FO-2	RFI Filter Assembly Schematic Diagram	

LIST OF TABLES

Table	Title	Page
1-1	Power Distribution Box Power and Signal Connections	1-4
3-1	DC Power Distribution Circuit Breakers	3-5
3-2	AC Power Distribution Circuit Breakers	3-7
5-1	Connector J1 Resistance Measurements.....	5-2
5-2	AC Output Neutral and Ground Pins	5-3
5-3	DC Output Connector Ground Measurements	5-3
5-4	Power Distribution Box Troubleshooting Procedure	5-6
5-5	AC Output Connectors Continuity Checks	5-14
5-6	DC Voltage Output Checks	5-15
B-1	Maintenance Allocation Chart for Distribution Box J-3986/ALQ-151(V)	B-3
B-2	Tool and Test Equipment Requirements for Distribution Box J-3986/ALQ-151(V)	B-4

SAFETY SUMMARY

The following are general precautions that are not related to any specific procedures and, therefore, do not appear elsewhere in this publication. These are recommended precautions that personnel must understand and apply during many phases of operation and maintenance.

KEEP AWAY FROM LIVE CIRCUITS

Operating personnel must at all times observe all safety regulations. Do not replace components or make adjustments inside the equipment with the high-voltage supply turned on. Under certain conditions, dangerous potentials may exist when the power control is in the off position, due to charges retained by capacitors. To avoid casualties, always remove power and discharge and ground a circuit before touching it.

DO NOT SERVICE OR ADJUST ALONE

Under no circumstances should any person reach into or enter the enclosure for the purpose of servicing or adjusting the equipment except in the presence of someone who is capable of rendering aid.

WARNING

The following warnings are used in the text of this volume and are repeated here for emphasis:

WARNING

High voltage is used in the operation of this equipment. Avoid contacting high-voltage connections when installing or repairing this equipment. Injury or death may result if personnel fail to observe safety precautions.

WARNING

Because of the power source arrangement, ac neutral and ground are not the same. It is possible for voltage potentials to exist between ac neutral and ground. These potentials may cause shock and personal injury. (Page 5-1)

WARNING

Adequate ventilation should be provided while using trichlorotrifluoroethane. Prolonged breathing of vapor should be avoided. The solvent should not be used near heat or open flame; the products of decomposition are toxic and irritating. Since trichlorotrifluoroethane dissolves natural oils, prolonged contact with skin should be avoided. When necessary, use gloves that the solvent cannot penetrate. If the solvent is taken internally, consult a physician immediately. (Page 5-19, 5-34, 5-35)

WARNING

Before performing any inspection, removal, replacement, or repair procedure, ensure that power is removed from the power distribution box. (Pages 5-15, 5-21, 5-22)

CHAPTER 1

INTRODUCTION

SECTION I. GENERAL

1-1. Scope. This manual provides organizational, direct support, and general support maintenance information, and repair parts and special tools list (RPSTL) for Distribution Box J-3986/ALQ-151(V) (see figure 1-1), hereinafter referred to as the power distribution box. In addition, the manual provides general information, tabulated data, and a functional description of the equipment. Refer to TM 32-5865-012-10 for organizational operating instructions for the power distribution box.

1-2. Maintenance Forms and Records. Department of the Army forms and procedures used for equipment maintenance will be those prescribed by TM 38-750, The Army Maintenance Management System (TAMMS).

1-3. Destruction of Army Materiel to Prevent Enemy Use. Procedures for the destruction of Army materiel are contained in TM 750-244-2, Procedures for Destruction of Electronics Materiel to Prevent Enemy Use (Electronics Command).

1-4. Administrative Storage. Refer to TM 740-90-1, Administrative Storage of Equipment, for test procedures, forms and records, and inspections required during administrative storage of this equipment.

1-5. Reporting of Errors. The reporting of errors, omissions, and recommendations for improving this publication by the individual user is encouraged. Reports should be submitted on DA Form 2028 (Recommended Changes to Publications) and forwarded directly to the Commander, U.S. Army Electronic Materiel Readiness Activity, EMRA, Vint Hill Farms Station, Warrenton, Virginia 22186, Attn: SELEM-ME-E.

1-6. Reporting Equipment Improvement Recommendations (EIR). EIRs will be prepared using SF 368, Quality Deficiency Report. Instructions for preparing EIRs are provided in TM 38-750, The Army Maintenance Management System (TAMMS). EIRs should be mailed directly to the Commander, U.S. Army Electronic Materiel Readiness Activity, EMRA, Vint Hill Farms Station, Warrenton, Virginia 22186, Attn: SELEM-ME-F. A reply will be furnished directly to you.

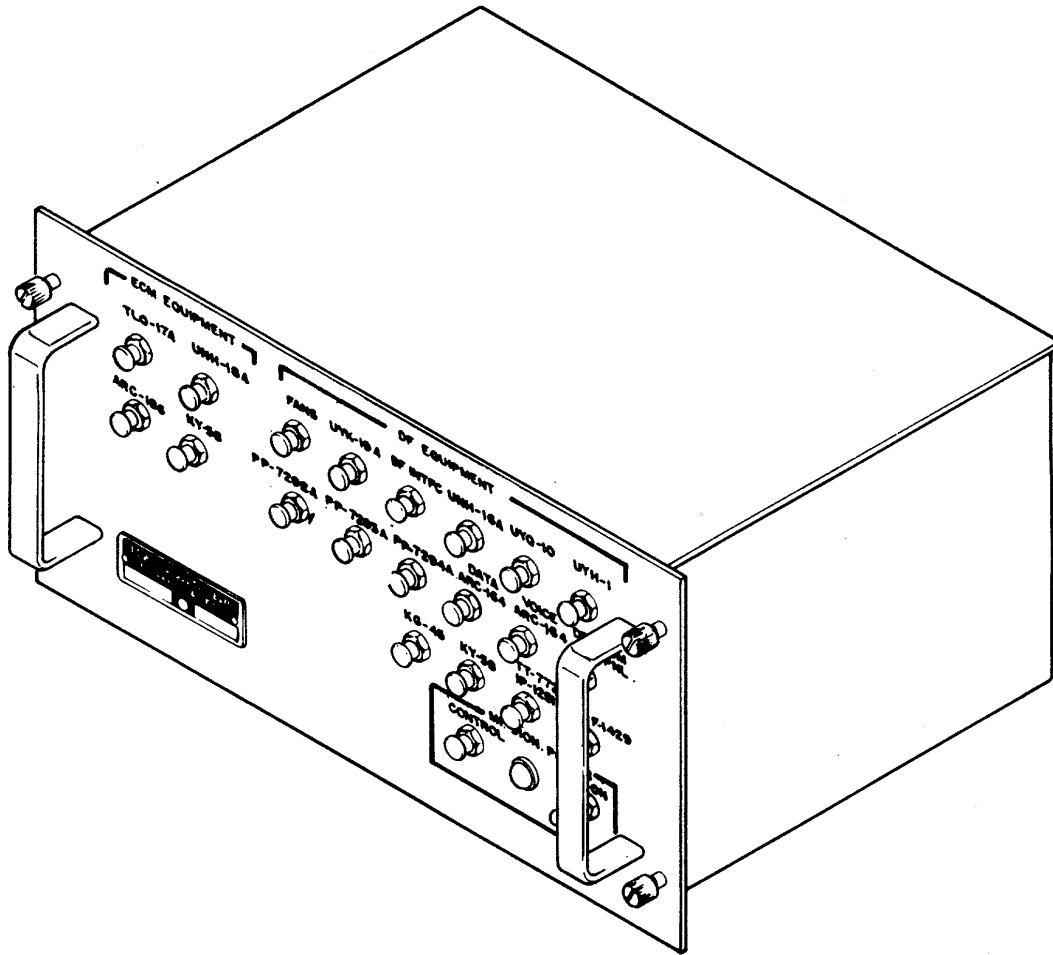

Figure 1-1. Distribution Box J-3986/ALQ-151(V)

SECTION II. DESCRIPTION AND DATA

1-7. Description. In addition to the description provided here, refer to TM 32-5865-012-10 for a general description and illustration of the power distribution box. The power distribution box is a metal enclosure containing 21 circuit breakers, one toggle switch, one lamp mounted on the front panel, and 11 multipin connectors mounted on the rear panel. Each circuit breaker protects a 115 V ac, 400-Hz, three-phase or a +28 V dc circuit to external line replaceable units (LRUs) in the system. The toggle switch operates relays in the power distribution box to control the application of power to some circuits and to function as an interlock control for another circuit. The lamp is illuminated when mission power is applied through the power distribution box to the LRUs in the system. In addition to the functions performed by the circuit breakers, the power distribution box contains interlock jumpers as safety features on input and output connectors. Rear panel connectors J9, J10, and J11 are part of an RF interference (RFI) filter assembly in the power distribution box. The RFI filter assembly filters six of the +28 V dc outputs. Power distribution box power and input/output connections are made at the rear panel (see table 1-1).

1-8. Tabulated Data.

Input/Output Power (ac)	115 V ac ($\pm 10\%$), 3-phase, 400-Hz
Input/Output Power (dc)	+28 V dc
Dimensions:	
Height	75 in (193 cm)
Depth	99 in (246 cm)
Width	145 in (363 cm)
Weight	35 lb (77 kg)
Environmental:	
Altitude	
Operating	30, 000 feet (maximum)
Nonoperating.....	40, 000 feet (maximum)
Temperature	
Operating	-40°C (-400F) to +55°C (+131°F)
Nonoperating.....	-57°C (-710F) to +85°C (+185°F)
Humidity.....	0 to 98%

Table 1-1. Power Distribution Box Power and Signal Connections

Connector marking	Pin	Function/Remarks
J1	A	No Connection
J1	B	No Connection
J1	C	115V ac 400 Hz Phase 1
J1	D	115V ac 400 Hz Phase 2
J1	E	115V ac 400 Hz Phase 3
J1	F	Neutral
J1	G	Ground
J2	A	No Connection
J2	B	115V ac 400 Hz Phase 1
J2	C	Neutral
J2	D	Ground
J2	E	115V ac 400 Hz Phase 1 PS1
J2	F	115V ac 400 Hz Phase 2
J2	G	115V ac 400 Hz Phase 3
J2	H	Neutral
J2	J	Neutral interlock
J2	K	Ground
J2	L	115V ac 400 Hz Phase 1 PS2
J2	M	115V ac 400 Hz Phase 2
J2	N	115V ac 400 Hz Phase 3
J2	P	Neutral interlock
J2	R	Neutral interlock
J2	S	Ground
J2	T	115V ac 400 Hz Phase 1 PS3
J2	U	115V ac 400 Hz Phase 2
J2	V	115V ac 400 Hz Phase 3
J2	W	Neutral interlock
J2	X	Neutral interlock
J2	Y	Ground
J2	Z	115V ac 400 Hz Phase 1 DF Control
J2	a	115V ac 400 Hz Phase 2
J2	b	115V ac 400 Hz Phase 3
J2	c	Neutral
J2	d	Neutral interlock
J2	e	Neutral interlock
J2	f	Ground
J2	g	115V ac 400 Hz Phase 1 Comm Proc.
J2	h	115V ac 400 Hz Phase 2
J2	i	115V ac 400 Hz Phase 3
J2	j	Neutral
J2	k	Neutral interlock
J2	m	Neutral interlock
J2	n	Ground
J2	p	115V ac 400 Hz Phase 1 RF Proc.
J2	q	115V ac 400 Hz Phase 2
J2	r	115V ac 400 Hz Phase 3

Table 1-1. Power Distribution Box Power and Signal Connections-Continued

Connector marking	Pin	Function/Remarks
J2	<u>s</u>	Neutral
J2	t	Neutral interlock
J2	<u>u</u>	Neutral interlock
J2	<u>v</u>	Ground
J2	<u>w</u>	115V ac 400 Hz Phase 1 RCU
J2	<u>x</u>	115V ac 400 Hz Phase 2
J2	<u>y</u>	115V ac 400 Hz Phase 3
J2	<u>z</u>	Neutral
J2	AA	Neutral interlock
J2	BB	Neutral interlock
J2	CC	Ground
J2	DD	115V ac 400 Hz Phase 2 IND CONT
J2	EE	Neutral
J2	FF	Neutral interlock
J2	GG	Neutral
J2	HH	Ground
J2	JJ	No Connection
J2	KK	No Connection
J2	LL	115V ac 400 Hz Phase 3
J2	MM	Neutral interlock
J2	NN	Ground
J2	PP	No Connection
J3	A	No Connection
J3	B	115V ac 400 Hz Phase 3
J3	C	Neutral
J3	D	Ground
J3	E	115V ac 400 Hz Phase 1
J3	F	115V ac 400 Hz Phase 1
J3	G	115V ac 400 Hz Phase 2
J3	H	115V ac 400 Hz Phase 2
J3	J	115V ac 400 Hz Phase 3
J3	K	115V ac 400 Hz Phase 3
J3	L	Neutral
J3	M	Neutral
J3	N	Ground
J3	P	Ground
J3	R	No Connection
J3	S	No Connection
J3	T	115V ac 400 Hz Phase 1
J3	U	Neutral
J3	V	Ground
J3	W	No Connection
J3	X	No Connection
J4	A	+28V dc
J4	B	Ground

Table 1-1. Power Distribution Box Power and Signal Connections-Continued

Connector marking	Pin	Function/Remarks
J4	C	+28V dc
J4	D	Ground
J4	E	No Connection
J4	F	No Connection
J4	G	No Connection
J4	H	No Connection
J4	J	No Connection
J4	K	No Connection
J4	L	No Connection
J4	M	No Connection
J4	N	No Connection
J4	P	No Connection
J4	R	No Connection
J4	S	No Connection
J5	A	No Connection
J5	B	No Connection
J5	C	No Connection
J5	D	+28V dc
J5	E	Ground
J5	F	+28V dc
J5	G	Ground
J5	H	No Connection
J5	J	No Connection
J5	K	No Connection
J5	L	No Connection
J5	M	+28V dc
J5	N	Ground
J5	P	No Connection
J5	R	No Connection
J5	S	No Connection
J5	T	No Connection
J5	U	+28V dc KY-58
J5	V	Ground
J5	W	Spare
J5	X	Spare
J5	Y	+28V dc
J5	Z	Ground
J5	a	Spare
J5	b	+28V dc
J5	c	Ground
J6	A	No Connection
J6	B	115V ac 400 Hz Phase 2
J6	C	Neutral
J6	D	Ground
J6	E	115V ac 400 Hz Phase 1

Table 1-1. Power Distribution Box Power and Signal Connections-Continued

Connector marking	Pin	Function/Remarks
J6	F	Neutral
J6	G	Ground
J6	H	No Connection
J7	A	No Connection
J7	B	+28V dc return ground
J7	C	No Connection
J7	D	No Connection
J7	E	+28V dc
J8	A	No Connection
J8	B	No Connection
J8	C	Switch in DF OP MISSION
J8	D	Switch out DF OP MISSION
J8	E	No Connection
J8	F	No Connection
J8	G	No Connection
J8	H	No Connection
J8	J	No Connection
J8	K	No Connection
J8	L	No Connection
J9	A	4-28V dc
J9	B	Ground
J9	C	+28V dc
J9	D	Ground
J9	E	Interlock Ind DF IND PANEL
J10	A	Spare
J10	B	Spare
J10	C	PS1 Overtemp
J10	D	PS2 Overtemp
J10	E	PS3 Overtemp
J10	F	Ground
J10	G	+28V dc to PS1
J10	H	PS1 Overtemp
J10	J	Ground
J10	K	Ground
J10	L	+28V dc to PS2
J10	M	PS2 Overtemp
J10	N	Ground
J10	P	Ground
J10	R	+28V dc to PS3
J10	S	PS3 Overtemp
J10	T	Ground
J10	U	Ground
J10	V	No Connection

Table 1-1. Power Distribution Box Power and Signal Connections-Continued

Connector marking	Pin	Function/Remarks
J11	A	No Connection
J11	B	+28V dc
J11	C	Ground
J11	D	+28V dc
J11	E	Ground
J11	F	+28V dc
J11	G	Ground
J11	H	+28V dc
J11	J	Ground
J11	K	No Connection

CHAPTER 2

ORGANIZATIONAL MAINTENANCE INSTRUCTIONS

2-1. Scope. Organizational support maintenance procedures are provided in TM 32-5865-012-20.

CHAPTER 3

FUNCTIONING OF EQUIPMENT

SECTION I. GENERAL

3-1. Scope. This chapter provides a functional description of the power distribution box. The circuits are explained to the extent necessary for general support maintenance.

3-2. Organization. In addition to the functional description contained herein, refer to TM 32-5865-012-10 for operating instructions for the power distribution box. The following description references block diagrams and schematic diagrams. Block diagrams are provided in the text or as foldout drawings. The schematic diagrams are provided as foldout drawings. Foldout drawings referenced in the text as FOs are located at the rear of the manual.

SECTION II. FUNCTIONAL DESCRIPTION

3-3. Power Distribution Box. Refer to figure FO-1. The power distribution box contains separate ac and dc control circuits, separate ac and dc power distribution circuits, and an RFI filter assembly. Safety features are provided in the form of interlock jumpers on two rear panel connectors.

a. *Control Circuits.* The ac and dc control circuits consist of relays K1 thru K4, switch S1, circuit breakers CB6 and CB21, and interlock jumpers on connector J2. As shown in figure 3-1, external equipments and switch functions are required to complete operation of the control circuits.

(1) *DC Control Circuit.* The +28 V dc input is applied to the power distribution box at connector pin J7-E. DC return is provided at connector pin J7-B. The input passes to the dc control circuit when CONTROL circuit breaker CB21 is set to on (in), the closure is made between connector pins J8-C and J8-D (normally switched by external equipment), and power distribution box MISSION POWER switch S1 is set to ON. The dc input illuminates MISSION POWER on lamp DS1 and operates relays K3 and K2. When relay K3 operates, contacts A1 and A2, B1 and B2, and C1 and C2 close to pass the +28 V dc input to circuit breakers CB9 thru CB20 in the dc power distribution circuit. When relay K2 operates, contacts A1 and A2, B1 and B2, and C1 and C2 close to pass the 115 V ac input to circuit breakers CB1 thru CB8 in the ac control and power distribution circuits.

(2) AC Control Circuit. The 115 V ac, three-phase input is applied to the power distribution box at connector pins J1-C, J1-D, and J1-E. AC neutral and ground are provided at connector pins J1-F and J1-G. The phase-one ac input passes to FANS circuit breaker CB6 when MISSION POWER switch S1 is set to ON and the relay K2 contacts close. When FANS circuit breaker CB6 is set to on (in), all three phases pass through terminal board TB3 and connector J2 to external LRUs in the system. The phase-one input through terminal board connection TB3-3 also operates relay K1 in the dc power distribution circuit and relay K4. When relay K4 operates, contacts A2 and A3 open to remove the ground from filter FL6 in the RFI filter assembly.

(3) Interlock Jumpers. The interlock circuit originates at the ac neutral line. The neutral potential is routed through the power distribution box and through external equipments in the system. The power distribution box interlock circuit consists of jumpers between connector pins J2-W and J2-R, J2-P and J2-J, J2-BB and J2-FF, J2-u and J2-AA, J2-t and J2-m, J2-k and J2-e, and J2-X and J2-d. When all of the external units are installed and connected, the ac neutral potential passes through connector pin J2-MM to the coil of relays K1 and K4. If any unit is removed or disconnected, the interlock circuit is opened and relays K1 and K4 cannot operate.

b. DC Power Distribution Circuit. The dc power distribution circuit provides individual paths through circuit breakers CB9 through CB20. As shown in figure 3-2, each circuit breaker protects a +28 V dc circuit to external units in the system or to filters FL1 through FL5 in the RFI filter assembly. Table 3-1 lists the panel marking and rating for each circuit breaker in the dc power distribution circuit. The following paragraphs describe the distribution paths protected by circuit breakers CB12 and CB20.

(1) Circuit Breaker CB12 Distribution. When PP-7294A circuit breaker CB20 is set to on (in), the +28 V dc power passes through connector pin J5-M to external equipment in the system.

(2) Circuit Breaker CB20 Distribution. When KG-45 circuit breaker CB20 is set to on (in), the +28 V dc power passes through connector pin J5-M to external equipment in the system.

c. AC Power Distribution Circuit. The ac power distribution circuit provides individual paths through circuit breakers CB1 through CB8. As shown in figure 3-3, each circuit breaker protects a 115 V ac circuit to external equipment in the system. Table 3-2 lists the voltage phase, panel marking, and rating of each circuit breaker. The following paragraphs describe the distribution paths protected by circuit breakers CB1 and CB2.

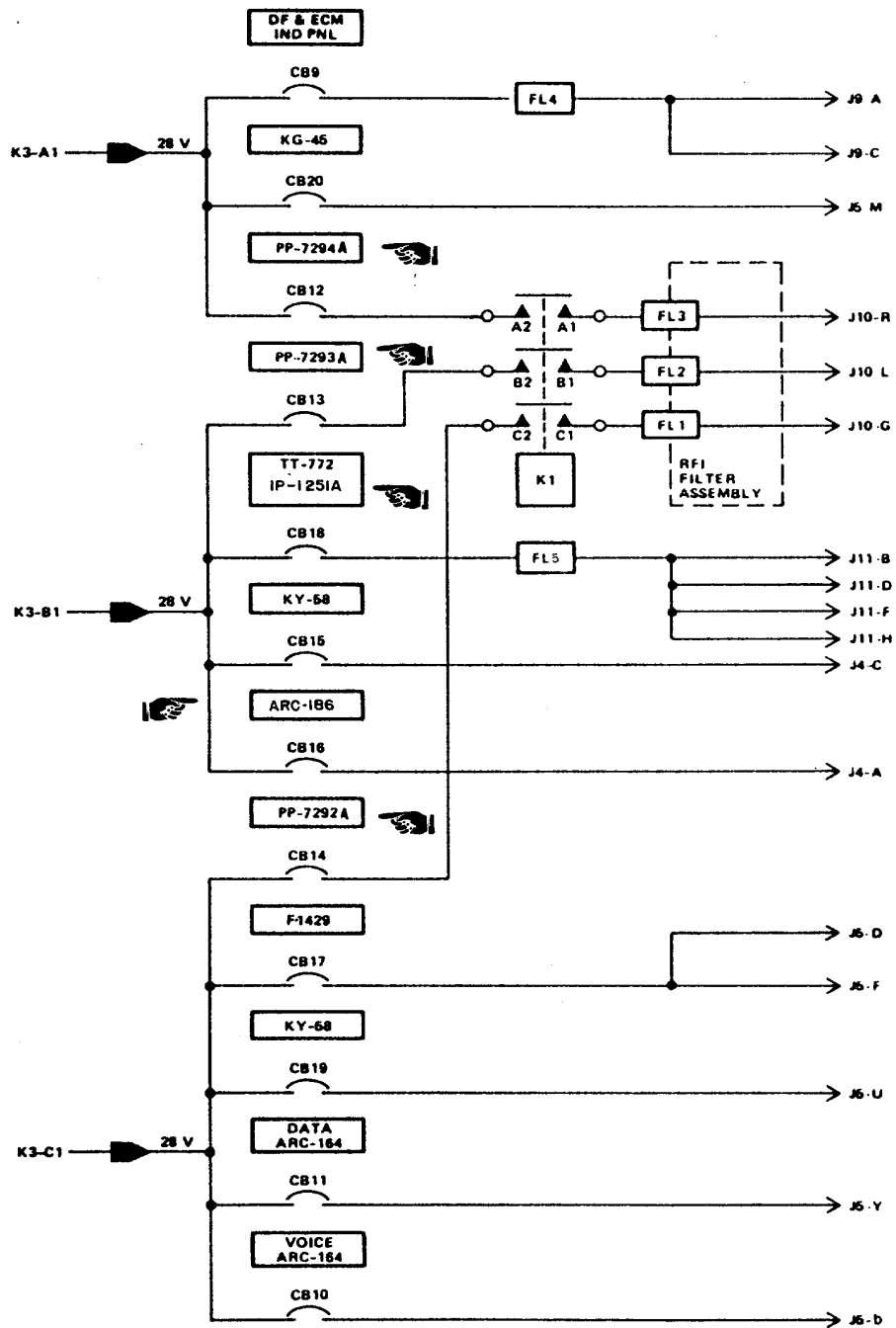
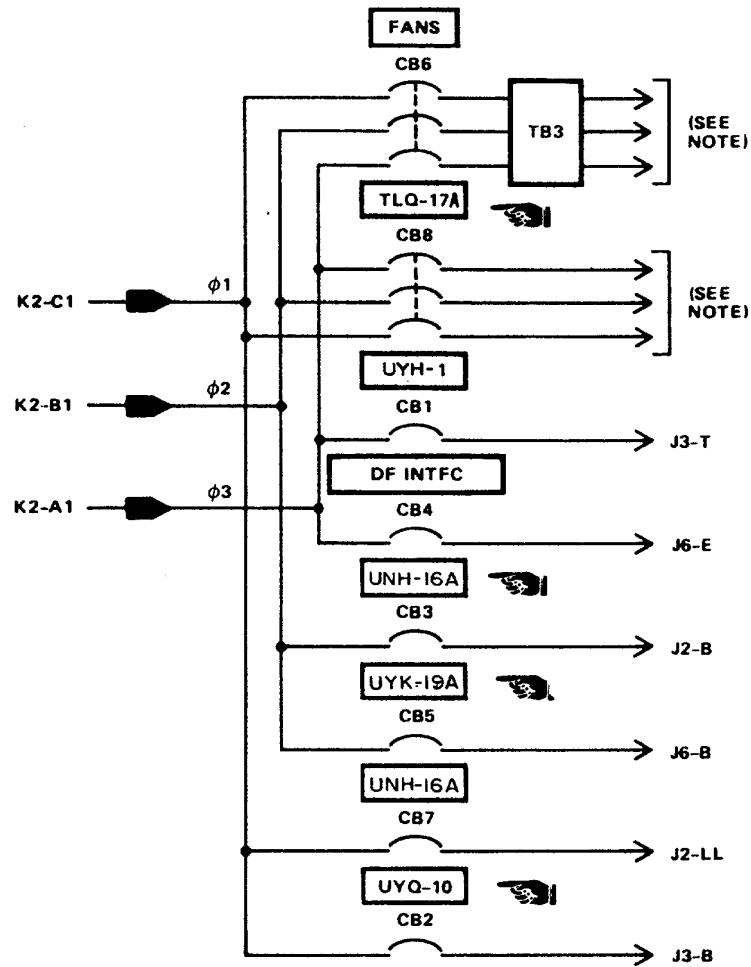

Figure 3-2. DC Power Distribution, Simplified Schematic Diagram

Table 3-1. DC Power Distribution Circuit Breakers

Circuit breaker	Panel marking	Ampere rating at 28 V dc
CB9	DF & ECM IND PNL	5
CB10	VOICE ARC-164	5
CB11	DATA ARC-164	5
CB12	PP-7294A	15
CB13	PP-7293A	15
CB14	PP-7292A	15
CB15	KY-58	1
CB16	AN/ARC-186	5
CB17	F1429	5
CB18 IP-1251A	TT-772	10
CB19	KY-58	1
CB20	KG-45	2



NOTE: THREE-PHASE OUTPUT CONNECTOR PINS ARE AS FOLLOWS:

CIRCUIT BREAKER	CONNECTOR	PIN		
		φ1	φ2	φ3
CB6	J2	E	DD	G
CB6	J2	<u>w</u>	F	N
CB6	J2	T	M	V
CB6	J2	L	U	b
CB6	J2	Z	a	y
CB6	J2	g	h	i
CB6	J2	<u>p</u>	<u>x</u>	r
CB8	J3	E	G q	J
CB8	J3	F	H	K

Figure 3-3. AC Power Distribution, Simplified Schematic Diagram

Table 3-2. AC Power Distribution Circuit-Breakers

Voltage phase	Circuit breaker	Panel marking	Ampere rating at 115 V ac
3	CB1	UYH-1	2
3	CB2	UYQ-10	5
2	CB3	UNH-16A	2
1	CB4	DF INTFC	5
2	CB5	UYK-19A	5
1, 2, 3	CB6	FANS	5
3	CB7	UNH-16A	2
1, 2, 3	CB8	TLQ-17A	25

(1) Circuit Breaker CB1 Distribution. When UYH-1 circuit breaker CB1 is set to on (in), the phase-one input passes through connector pin J3-T to external equipment in the system.

(2) Circuit Breaker CB2 Distribution. When UYQ-10 circuit breaker CB2 is set to on (in), the phase-three input passes through connector pin J3-B to external equipment in the system.

d. RFI Filter Assembly. Refer to figure FO-2. The RFI filter assembly contains filters FL1 thru FL6 and interlock jumpers on connector J10. Filters FL1 through FL5 receive +28 V dc from circuit breakers CB9, CB18, and CB12 through CB14. Filter FL6 receives ground from relay K4. The filters reduce fluctuations caused by circuit breaker and/or relay operation. The interlock jumpers between connector pins J10-E and J10-S, J10-D and J10-M, and J10-C and J10-H protect overtemperature circuits to three external units. If connector J10 is removed, the interlock circuits are opened and the external units cannot operate.

CHAPTER 4

DIRECT SUPPORT MAINTENANCE INSTRUCTIONS

SECTION I. GENERAL

4-1. Scope. No direct support maintenance is required for this equipment. Units removed during organizational maintenance are forwarded to the general support level for maintenance as described in chapter 5.

CHAPTER 5

GENERAL SUPPORT MAINTENANCE INSTRUCTIONS

SECTION I. GENERAL

5-1. Scope. This chapter provides general support maintenance instructions for the power distribution box. Troubleshooting and test procedures in this chapter supplement maintenance instructions provided in TM 32-5865-012-20 by using additional test equipment, tools, and materials available to general support maintenance.

5-2. Organization. This chapter contains tables of reference data and measurements that are made on the power distribution box to determine proper operation. This chapter also references the tools and test equipment required and provides a troubleshooting procedure. In addition, the chapter provides maintenance and test procedures to the component level for general support maintenance.

5-3. Measurements and Data. Input power is 115 V ac, three-phase, 400-Hz. The three voltage phases are derived from a Y-wound transformer. Each voltage phase is measured between one leg of the Y and the center ac neutral. A chassis ground is also provided. Measurements made between a voltage phase line and chassis ground are not valid.

WARNING

Because of the power source arrangement, ac neutral and ground are not the same. It is possible for voltage potentials to exist between ac neutral and ground. These potentials may cause shock and personal injury.

CAUTION

Remove power before making resistance checks.

a. AC Power Resistance Checks. Table 5-1 lists measurements and data for the ac power input at connector J1. The data is used for resistance checks.

Table 5-1. Connector J1 Resistance Measurements

From	To	Resistance
J1-C	J1-F	Open circuit
J1-D	J1-F	Open circuit
J1-E	J1-F	Open circuit
J1-F	J1-G	Greater than 1.0 megohm
J1-G	Chassis Ground Stud	Less than 0.50 ohm

CAUTION

Remove power before making resistance checks.

b. DC Power Resistance Checks. Resistance checks are made at two points on dc power input connector J7. Check for an open circuit between connector pins J7-E and J7-B. Verify that less than 0.10 ohm is present between connector pin J7-B and the chassis ground stud.

c. AC Connectors Neutral and Ground Checks. Table 5-2 lists measurements and data for the ac power output at connectors J2, J3, and J6. Each line lists related neutral and ground connector pins that are used for resistance measurements. The data is used to verify the following conditions:

- (1) More than 1.0 megohm is present between each related neutral and ground connector pin listed.
- (2) Less than 0.5 ohm is present between all neutral connector pins listed.
- (3) Less than 0.5 ohm is present between the chassis ground stud and each ground connector pin listed.

d. DC Connectors Ground Checks. Table 5-3 lists measurements and data for the dc power output at connectors J4, J5, and J9 thru J11. The data is used to verify that less than 0.5 ohm is present between the chassis ground stud and each connector pin listed.

Table 5-2. AC Output Neutral and Ground Pins

Neutral	Ground
J3-M	J3-N
J2-c	J2-f
J2-i	J2-n
J2-z	J2-CC
J2-EE	J2-HH
J2-s	J2-v
J2-H	J2-K
J2-W*	J2-Y
J2-P*	J2-S
J2-C	J2-D
J2-GG	J2-NN
J3-C	J3-D
J3-U	J3-V
J6-C	J6-D
J6-F	J6-G

*Neutral pin not connected without external interlock.

Table 5-3. DC Output Connector Ground Measurements

Pin	Signal
J10-J	PP-7292A Power Supply
J10-N	PP-7293A Power Supply
J10-T	PP-7294A Power Supply
J9-B	DF Indicator Panel
J11-C	TT-772 Printer
J11-E	Panoramic Indicator
J11-G	28Vdc Return
J5-c	Voice Channel ARC-164
J5-Z	Data Channel ARC-164
J5-V	Comm Link KY-58
J5-E	Data Link F-1429
J5-G	Voice Link F-1429
J5-N	Data Link KG-45
J4-B	ARC-186 Comm Set
J4-D	Comm Set KY-58

SECTION II. TOOLS AND EQUIPMENT

5-4. General. This section lists the tools, test equipment, and materials required to perform general support maintenance.

5-5. Tools and Equipment Required. Lists of authorized common tools and equipment are provided as part of the Maintenance Allocation Chart (MAC) located in Appendix B of this manual. Appendix D of this manual is a list of expendable supplies and materials required.

SECTION III. TROUBLESHOOTING

5-6. General. This section provides troubleshooting instructions for the power distribution box.

5-7. Power Distribution Box Procedure. Troubleshooting of the power distribution box consists of a series of checks that verify that all components function properly. The procedure assumes that system level troubleshooting by organizational maintenance personnel has been performed as given in TM 32-5865-012-20 to isolate the problem to the power distribution box. After performing general inspection and cleaning procedures in section IV of this chapter, refer to table 5-4 for the troubleshooting procedure. Figures 5-1 and 5-2 show test equipment connections referenced in the troubleshooting procedure. Tables 5-5 and 5-6 list test points referenced in the troubleshooting procedure. After the problem is isolated, refer to section IV of this chapter for the appropriate maintenance procedure.

Table 5-4. Power Distribution Box Troubleshooting Procedure

Step	Test Point	Test Equipment	Procedure	Normal Indication	If Indication is Normal	If Indication is Abnormal
1	J1,J7,J2,J10, J3,J6, J9,J11, J5,J4		<p style="text-align: center;">NOTE</p> <p>This procedure includes the major components that may be defective within the power distribution box. The procedure does not test point-to-point wiring within the power distribution box.</p> <p>Perform measurement checks described in paragraph 5-3.</p>	As given in paragraph 5-3.	Proceed with step 2	Do not apply power to the unit. Repair wiring and proceed with step 2 when all measurements are correct.
2	MISSION POWER Indicator ON	Power supply, multimeter, Connector assembly P8, Test cable W1	<p style="text-align: center;"><u>DC Input Tests</u></p> <p>a. Verify all circuit breakers are set to on (in) position and MISSION POWER switch is set to off (down) position.</p> <p style="text-align: center;">WARNING</p> <p>Ground chassis before applying power.</p> <p>b. Turn power supply on and set for +28 V dc output.</p>			

Table 5-4. Power Distribution Box Troubleshooting Procedure - Continued

Step	Test Point	Test Equipment	Procedure	Normal Indication	If Indication is Normal	If Indication is Abnormal
2 Cont			c. Use multimeter to verify power supply output. d. Establish test setup shown in figure 5-1. e. Set power distribution box MISSION POWER switch to ON (up). MISSION POWER ON indicator goes out.	MISSION POWER ON indicator lights. Proceed with step 3.	Replace CONTROL circuit breaker CB21.	Replace MISSION POWER ON light, MISSION POWER switch S1 and/or CONTROL circuit breaker CB21.
3	J1, J2, J3, J6	Same as step 2.	a. Set CONTROL circuit breaker CB21 to on (in) position. Measure continuity between the From and To connector pins listed in table 5-5.	Short circuit for each check.		If open at all connector pins, replace relay K2. If open at only one point, replace related circuit breaker (see table 5-5). If open at all functions for one phase, replace relay K2.

Table 5-4. Power Distribution Box Troubleshooting Procedure - Continued

Step	Test Point	Test Equipment	Procedure	Normal Indication	If Indication is Normal	If Indication is Abnormal
4 Cont			c. Wait approximately 5 minutes, then repeat step 4a. d. Set circuit breakers CB9 thru CB11 and CB15 thru CB20 to on (in) position. (See figure 5-3.) <u>AC Input Tests</u>	OV for each check.		If voltage present at any connector pin, replace relate circuit breaker (see table 5-6).
5	J10	Power supply, Multimeter, Connector assembly P8, Test cable W1, Test cable W2 Connector Assembly P2	a. Set MISSION POWER switch to off (down) position. <u>WARNING</u> Ground chassis before applying power b. Establish test setup shown in figure 5-2.. c. Set MISSION POWER switch to ON (up). d. Refer to figure FO-1. with multimeter connected to J1-F, measure all 115V ac output circuits.	115V ac	Proceed with step 5.	If all outputs are defective, check relay K2 coil circuits and replace K2 if necessary

Table 5-4. Power Distribution box Troubleshooting Procedure - Continued

Step	Test Point	Test Equipment	Procedure	Normal Indication	If Indication is Normal	If Indication is Abnormal
5 Cont			<p>e. With multimeter connected to ground stud , measure voltage at connector pins J10-G, J10-R, and J10-L.</p> <p>f. Set circuit breakers CB12 through CB14 to off (out) position and turn power supply off. Connect a 600 ohm, 2 W resistor between J10-L and ground to bleed off the in-line filter discharge. Monitor the discharge with a multimeter. Repeat the procedure for J10-G and J10-R. (See figure 5-3.)</p>	<p>+28 V dc for each check.</p> <p>+28 V dc slowly bleeding down to 0 volts.</p>	<p>Proceed with step 6.</p>	<p>If voltage missing at connector pin J10-G, replace circuit breaker CB14, filter FL1, or relay K1.</p> <p>If voltage missing at connector pin J10-R, replace circuit breaker CB12 filter FL3, or relay K1.</p> <p>If voltage missing at connector pin J10-L, replace circuit breaker CB13 filter FL2, or relay K1.</p> <p>If voltage present at J10-L, J10-G or J10-R, replace related circuit breaker.</p>

Table 5-4. Power Distribution Box Troubleshooting Procedure - Continued

Step	Test Point	Test Equipment	Procedure	Normal Indication	If Indication is Normal	If Indication is Abnormal
6	J9-D, J10-G	Same as step 5.	a. Turn power supply on. Set circuit breakers CB12 thru CB14 to on (in) position. 28 V power supply must be turned on. (See figure 5-3.) b. Measure- voltage between connector pins J9-E (-) and J10-G (+). c. Set FANS circuit breaker CB6 to off (out) position and repeat step 6b.	0 V dc. +28 V dc. Slowly bleeding down to 0 volts.	Proceed with step 7.	Replace relay K4 or filter FL6. Replace relay K4 or filter FL6.
7			a. Turn power supply off. b. Disconnect all test equipment.		Test Completed	

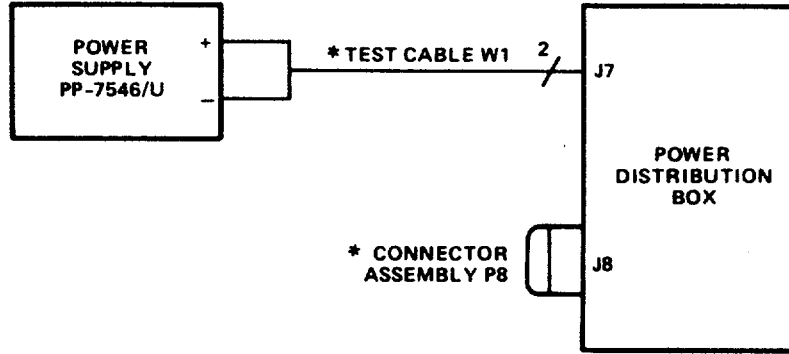

* See Appendix E for fabrication procedures.

Figure 5-1. DC Input Test Setup

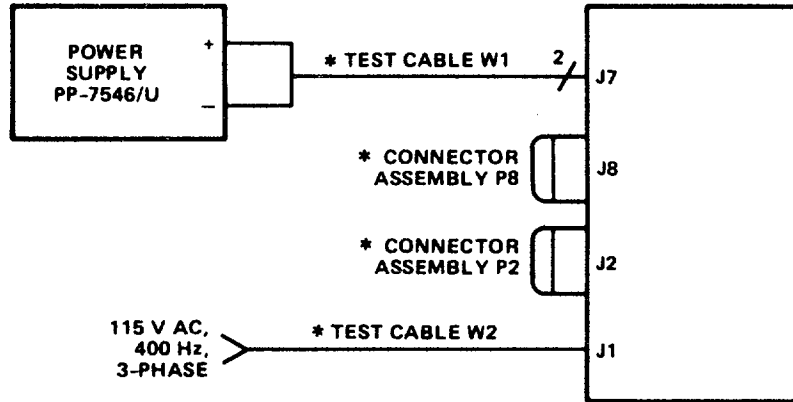

* See Appendix E for fabrication procedures.

Figure 5-2. AC Input Test Setup

Table 5-5. AC Output Connectors Continuity Checks

From	To	Circuit breaker	Function
J1-C	J2-E	CB6 (FANS)	Phase 1
J1-C	J2-L	CB6 (FANS)	Phase 1
J1-C	J2-T	CB6 (FANS)	Phase 1
J1-C	J2-Z	CB6 (FANS)	Phase 1
J1-C	J2-g	CB6 (FANS)	Phase 1
J1-C	J2-p	CB6 (FANS)	Phase 1
J1-C	J2-w	CB6 (FANS)	Phase 1
J1-C	J3-E	CB8 (TLQ-17A)	Phase 1
J1-C	J3-F	CB8 (TLQ-17A)	Phase 1
J1-C	J3-T	CB1 (UYH-1)	Phase 1
J1-C	J6-E	CB4 (DF INTFC)	Phase 1
J1-D	J2-B	CB3 (UNH-16A)	Phase 2
J1-D	J2-F	CB6 (FANS)	Phase 2
J1-D	J2-M	CB6 (FANS)	Phase 2
J1-D	J2-U	CB6 (FANS)	Phase 2
J1-D	J2-a	CB6 (FANS)	Phase 2
J1-D	J2-h	CB6 (FANS)	Phase 2
J1-D	J2-g	CB6 (FANS)	Phase 2
J1-D	J2-x	CB6 (FANS)	Phase 2
J1-D	J2-DD	CB6 (FANS)	Phase 2
J1-D	J3-G	CB8 (TLQ-17A)	Phase 2
J1-D	J3-H	CB8 (TLQ-17A)	Phase 2
J1-D	J6-B	CB5 (UYK-19A)	Phase 2
J1-E	J2-G	CB6 (FANS)	Phase 3
J1-E	J2-N	CB6 (FANS)	Phase 3
J1-E	J2-V	CB6 (FANS)	Phase 3
J1-E	J2-b	CB6 (FANS)	Phase 3
J1-E	J2-i	CB6 (FANS)	Phase 3
J1-E	J2-r	CB6 (FANS)	Phase 3
J1-E	J2-y	CB6 (FANS)	Phase 3
J1-E	J3-J	CB8 (TLQ-17A)	Phase 3
J1-E	J3-K	CB8 (TLQ-17A)	Phase 3
J1-E	J2-LL	CB7 (UNH-16A)	Phase 3
J1-E	J3-B	CB2 (UYQ-10)	Phase 3

Table 5-6. DC Voltage Output Checks

Connector pin	Circuit breaker
J4-A	CB16 (ARC-186)
J5-D	CB17 (F1429)
J5-M	CB20 (KG-45)
J5-Y	CB11 (DATA ARC-164)
*J11-H	CB18 (IP-1251A & TT-772)
*J11-D	CB18 (IP-1251A & TT-772)
*J9-A	CB9 (DF & ECM IND PNL)
J4-C	CB15 (KY-58)
J5-F	CB17 (F1429)
J5-U	CB19 (KY-58)
J5-b	CB10 (VOICE ARC-164)
*J11-B	CB18 (IP-1251A & TT-772)
*J11-F	CB18 (IP-1251A & TT-772)
*J9-C	CB9 (DF & ECM IND PNL)

* Voltage bleeds slowly after circuit breaker is pulled due to in-line filters.

SECTION IV. MAINTENANCE OF POWER DISTRIBUTION BOX

5-8. General. This section provides maintenance procedures that are the responsibility of general support maintenance personnel. Paragraph 5-9 contains general inspection and cleaning instruction for the power distribution box. Subsequent paragraphs contain specific maintenance procedures applicable to power distribution box components shown in figures 5-3 and 5-4. Procedures reference components by parenthetical numbers keyed to figures 5-3 and 5-4. Perform both the general procedures and the applicable specific procedures.

5-9. Maintenance Procedures. Remove the top and bottom covers as given in paragraph 5-10a and perform the following items.

WARNING

Before performing any inspection procedure, ensure that power is disconnected from the distribution box.

a. Inspection.

- (1) Inspect the exterior of the unit for dirt, corrosion, dents, scratches, and chipped paint.

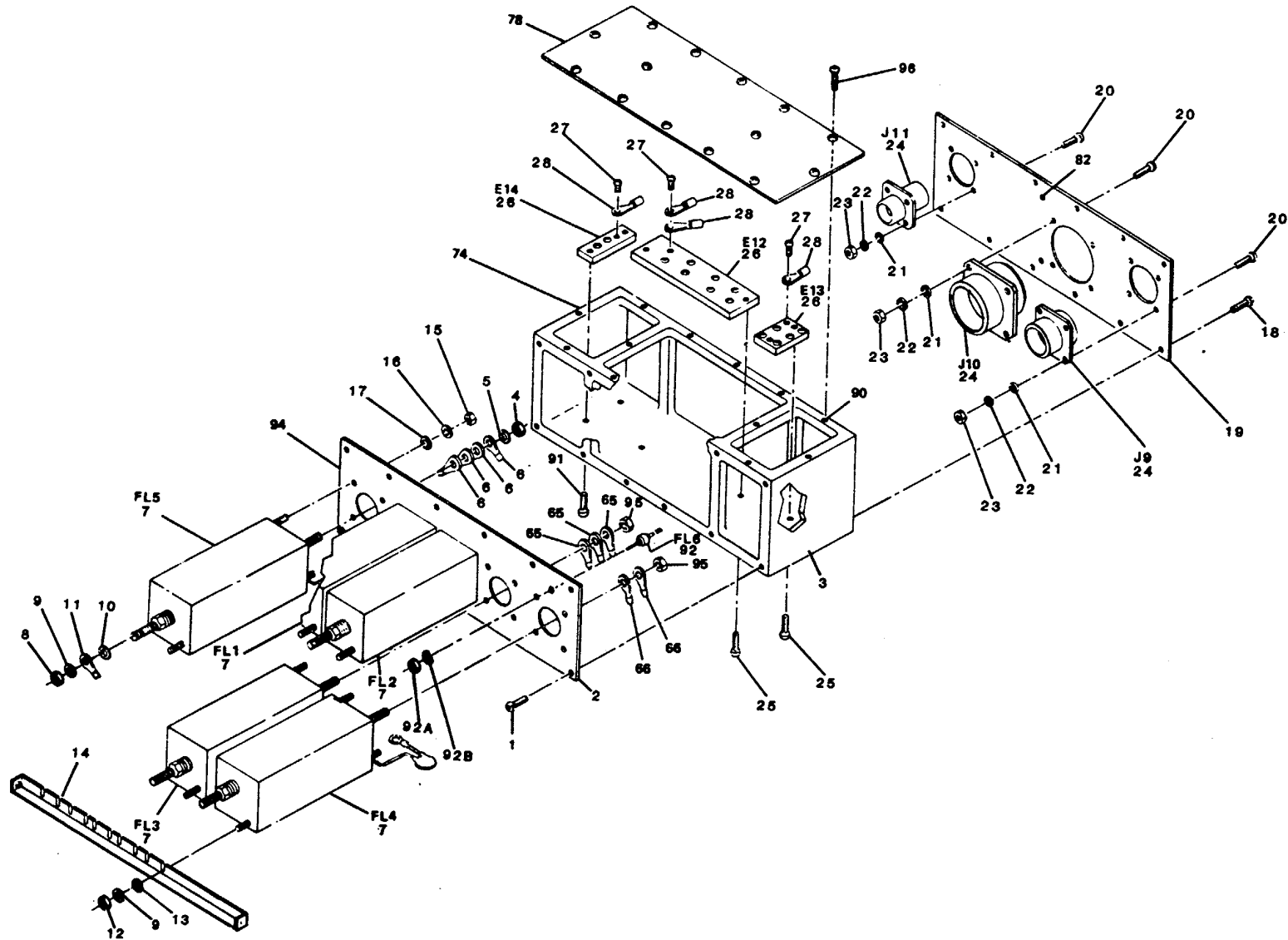

Figure 5-4. Filter FL1 through FL5 Replacement

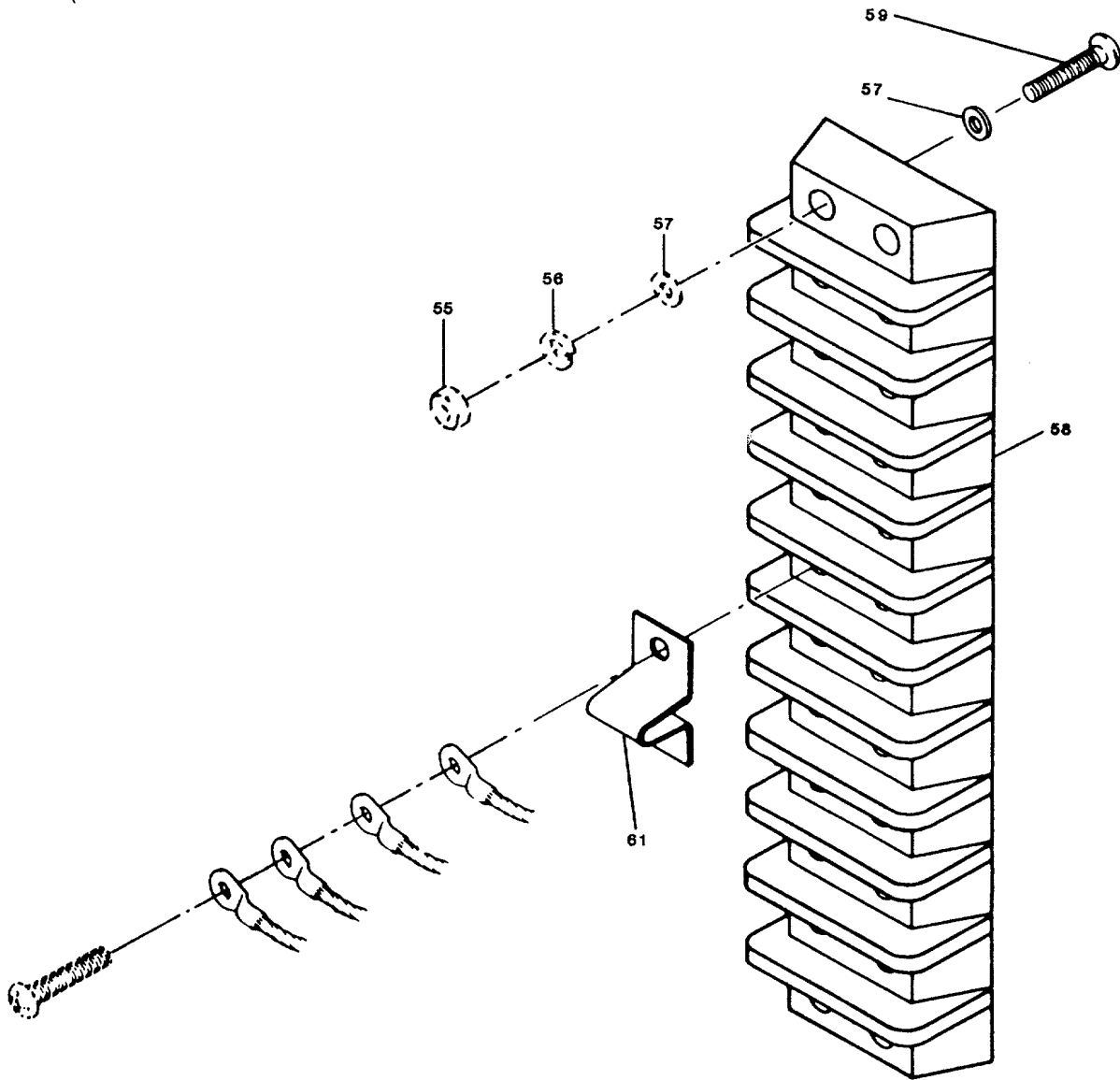

Figure 5-5. Connecting Link Replacement

- (2) Check cable connectors for correct pin depths.
- (3) Inspect the interior of the unit for dirt, corrosion, and foreign objects.
- (4) Inspect the interior of the unit for burned, frayed, broken, or loose wires. Inspect for kinks and strained, cut, frayed, or otherwise damaged insulation.
- (5) Inspect cable connectors for broken or shorted wires.
- (6) Inspect switch contacts for dirt, dust, and/or corrosion.
- (7) Inspect for loose or missing screws from connectors, chassis, or terminal boards.
- (8) Inspect circuit breaker contacts for dirt, dust, and/or corrosion.

b. Cleaning.

- (1) Remove dust and loose dirt from exterior surfaces with a clean, soft cloth (item 4, App. D).
- (2) Remove dust and dirt from cable connectors, internal wiring, terminal strips, and other surfaces with a soft brush (item 2, App. D).

WARNING

Adequate ventilation should be provided while using trichlorotrifluoroethane. Prolonged breathing of vapor should be avoided. The solvent should not be used near heat or open flame; the products of decomposition are toxic and irritating. Since trichlorotrifluoroethane dissolves natural oils, prolonged contact with skin should be avoided. When necessary, use gloves (item 6, App. D) that the solvent cannot penetrate. If the solvent is taken internally, consult a physician immediately.

- (3) Remove grease and/or dirt with a cloth dampened (not wet) with trichlorotrifluoroethane (item 13, App. D).

5-10. Removal Procedures. Removal procedures are provided for the top cover, bottom cover, high-voltage shield, and RFI filter assembly A1 to gain access to the items replaced during repair procedures.

WARNING

Before performing any removal procedure, ensure that power is disconnected from the power distribution box.

- a. Top and Bottom Cover Removal. Refer to figure 5-3. Loosen the 20 self retaining screws (1) around the perimeter of the top cover (2) or bottom cover (3). Remove the cover.
- b. High-Voltage Shield Removal. Refer to figure 5-3. Remove the top cover in accordance with paragraph 5-10a, then remove the six screws (4) and the high-voltage shield (5).
- c. RFI Filter Assembly A1 Removal. Refer to figures 5-3 and 5-4, and proceed as follows:
 - (1) Remove bottom cover (3) in accordance with paragraph 5-10a.
 - (2) Remove the six screws (7), flat washers (8), and lock washers (9) that secure the RFI filter assembly (6) to the rear of the chassis.
 - (3) Remove the two screws (10) that secure the filter bracket (11) to the sides of the chassis.
 - (4) Slide the RFI filter assembly (6), with filter bracket attached, toward the front panel to clear the connectors from the rear panel, then turn the assembly sideways until the filter bracket is free of the chassis. Note that the connection to filter FL6 (12) is hidden behind FL4 (63).
 - (5) Refer to figure 5-4. Tag the wires on the RFI filter assembly (6) for proper identification during reconnection. Remove nut (8), lock washer (9), flat washer (10), terminal lug (11), and wiring from FL1 through FL5 (7).
 - (6) Tag wire connected to FL6 (item 92, figure 5-4) for proper identification during reconnection, then unsolder wire.
 - (7) Refer to figure 5-3. Remove the RFI filter assembly (6) from the chassis. Refer to figure 5-4. Remove two nuts (12) two flat washers (9) and two lock washers (13) that secure filter bracket (14) to each filter and remove filter bracket (14).

5-11. Replacement Procedures. Replacement procedures are provided for the RFI filter assembly A1, the high-voltage shield, and the top and bottom covers.

WARNING

Before performing any replacement procedure, ensure that power is removed from the distribution box.

a. RFI Filter Assembly A1 Replacement. Refer to figure 5-3 unless otherwise indicated and proceed as follows:

- (1) Place the RFI filter assembly (6) in position for soldering the wire to filter FL6 (92) as tagged during removal.
- (2) Solder the wire to FL6 (92).
- (3) Refer to figure 5-4. Secure filter bracket (14) to filters FL1 through FL5 (7) with two lock washers (13), two flat washers (9) and two nuts (12) at each filter.
- (4) Refer to figure 5-4. Reconnect wiring to filters FL1 through FL5 (7) as tagged during removal. Secure terminal lug (11) with nut (8), lock washer (9), and flat washer (10) at each filter.
- (5) Carefully rotate the RFI filter assembly and install it into its correct position inside the chassis.
- (6) Secure the filter bracket (11) to the sides of the chassis with two screws (10).
- (7) Secure the RFI filter assembly to the rear panel with six screws (7), flat washers (8), and lock washers (9).
- (8) Install the bottom cover (3) in accordance with paragraph 5-11c.
- (9) Refer to section V of this chapter.

b. High-Voltage Shield Replacement. Refer to figure 5-3. Aline the high-voltage shield (5) in the chassis and secure with six screws (4). Replace top cover (2) in accordance with paragraph 5-1c.

c. Top and Bottom Cover Replacement. Refer to figure 5-3. Aline the top cover (2) or bottom cover (3) in the chassis and secure with 20 screws (1).

5-12. Repair Procedures. Repair procedures consist of replacing a defective subassembly, electrical component or hardware item.

WARNING

Before performing any repair procedure, ensure that power is removed from the power distribution box.

a. MISSION POWER Switch S1 Removal and Replacement. Refer to figure 5-3 and proceed as follows:

- (1) Remove the bottom cover (3) as given in paragraph 5-10a.
- (2) Remove the outer collar nut (14) and outer lock washer (15) that secure the switch (13) to the front panel (16). Remove the switch.
- (3) Tag the wires to identify switch (13) connections.
- (4) Remove the wires from the switch (13).
- (5) Attach the wires to the replacement switch (13) as tagged during removal.
- (6) Remove the outer collar nut (14) and outer lock washer (15) from the replacement switch. Aline the switch with top side up and slide into the front panel (16). Adjust the inner collar nut (17) to accommodate the keyed washer (17A), outer lock washer (15) and outer collar nut (14).
- (7) Secure the switch (13) to the front panel (16) with the outer lock washer (15) and the outer collar nut (14).
- (8) Reinstall the bottom cover (3) in accordance with paragraph 5-11c.
- (9) Refer to section V of this chapter.

b. Circuit Breaker Removal and Replacement. Refer to figures 5-3 and 5-6 and proceed as follows:

- (1) If needed, remove the top cover (2) and the bottom cover (3) in accordance with paragraph 5-10a.

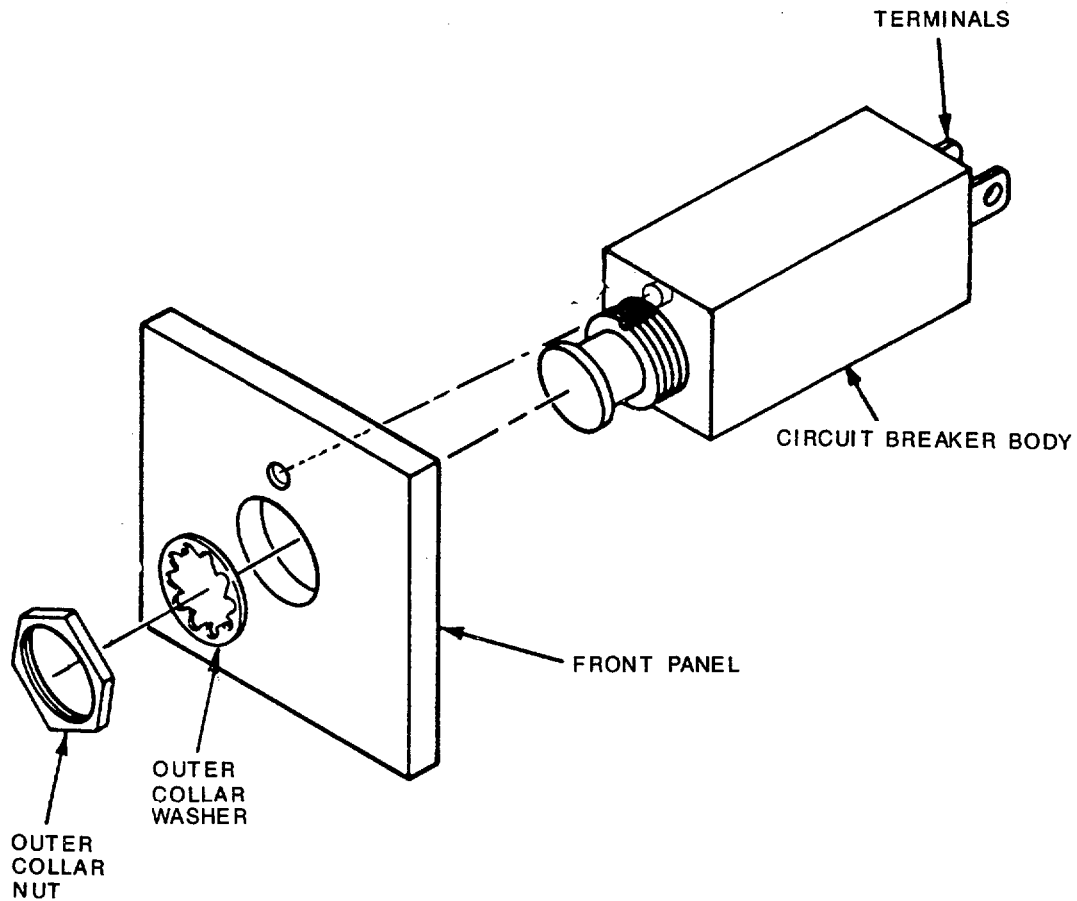

Figure 5-6. Circuit Breaker Replacement

- (2) If needed, remove the high-voltage shield (5) in accordance with paragraph 5-10b, and the RFI filter assembly (6) in accordance with paragraph 5-10c.
- (3) Remove the collar nut (19) and lock washer (20) that secure the circuit breaker (18) to the front panel (16). Remove the circuit breaker.
- (4) Tag the wires to identify circuit breaker (18) connections.
- (5) Remove the wires from the circuit breaker (18).
- (6) Attach the wires to the replacement circuit breaker (18) as tagged.
- (7) Remove the collar nut (19) and lock washer (20) from the replacement circuit breaker. Align the circuit breaker in the front panel (16).

- (8) Secure the circuit breaker (18) to the front panel (16) with the lock washer (20) and collar nut (19).
- (9) If removed, install the high-voltage shield (5) in accordance with paragraph 5-11b.
- (10) If removed, install the bottom cover (3) and the top cover (2) in accordance with paragraph 5-11c.
- (11) Refer to section V of this chapter.

c. Relay K4 Removal and Replacement. Refer to figure 5-3 and proceed as follows:

- (1) Remove top cover (2) in accordance with paragraph 5-10a.
- (2) Remove the high-voltage shield (5) in accordance with paragraph 5-10b.
- (3) Using thin-walled socket tool TMD-16 and 1/4 inch drive wrench remove the two nuts (21) and flat washers (22) that secure the relay (23) to socket XK4 (24).
- (4) Pull the relay (23) out of the socket (24).
- (5) Using thin-walled socket tool TMD-16 and 1/4 inch drive wrench install the replacement relay in socket XK4 (24) and secure with two nuts (21) and flat washers (22).
- (6) Install the high-voltage shield (5) in accordance with paragraph 5-11b, then replace top cover (2) in accordance with paragraph 5-11c.
- (7) Refer to section V of this chapter.

d. Socket XK4 Removal and Replacement. Refer to figure 5-3 and proceed as follows:

- (1) Remove top cover (2) and bottom cover (3) in accordance with paragraph 5-10a. Remove high voltage shield in accordance with paragraph 5-10b.
- (2) Remove RFI filter assembly A1 (6) in accordance with paragraph 5-10c, steps (1) through (4).
- (3) Remove relay K4 (23) in accordance with paragraph 5-12c.
- (4) Remove associated two nuts and washers that secure socket XK4 (24) to component shelf (27).
- (5) Tag each wire for proper identification and remove from socket (24).
- (6) To replace socket (24), attach wires as marked during removal, insert socket through opening in component shelf (27), and secure with associated two nuts and washers.

- (7) Install relay K4 (23) in accordance with paragraph 5-12c.
- (8) Install RFI filter assembly A1 (6) in accordance with paragraph 5-11a.
- (9) Replace high voltage shield (5) in accordance with paragraph 5-11b. Install top cover (2) and bottom cover (3) in accordance with paragraph 5-11c.
- (10) Refer to section V of this chapter.

e. Relay K1, K2, or K3 Removal and Replacement. Refer to figure 5-3 and proceed as follows:

- (1) Remove top cover (2) and bottom cover (3) in accordance with paragraph 5-10a.
- (2) Remove the high voltage shield (5) in accordance with paragraph 5-10b and RFI filter assembly A1 (6) in accordance with 5-10c, steps (1) through (4).
- (3) Tag the terminal lugs (29) for proper identification during reconnection, then remove the nuts (28) that secure the terminal lugs (29) to the relay (30) to be replaced.
- (4) Remove the four screws (31), lock washers (32), flat washers (33), and standoffs (34). Remove the relay to be replaced.
- (5) Place the replacement relay in mounting position and secure to the component shelf (27) with the four screws (31), lock washers (32), flat washers (33), and two standoffs (34).
- (6) Attach each terminal lug (29) to the relay (30) as tagged and secure with the nuts (28).
- (7) Replace RF1 filter assembly A1 (6) in accordance with paragraph 5-11a.
- (8) Install the high-voltage shield (5) in accordance with paragraph 5-11b, then replace top cover (2) and bottom cover (3) in accordance with paragraph 5-11c.
- (9) Refer to section V of this chapter.

f. Filter FL1 through FL5 Removal and Replacement. Refer to 5-4 unless otherwise indicated and proceed as follows:

- (1) Remove bottom cover (3) (figure 5-3) in accordance with paragraph 5-10a.

- (2) Remove RFI filter assembly (6) (figure 5-3) from the chassis in accordance with paragraph 5-10c, steps (1) through (5).
- (3) Remove 12 flat-head screws (1) from the filter-mounted side of the RFI assembly. Carefully lift filters and attached front plate (2) from filter chassis (3).
- (4) Tag wires to the filter to be removed for proper identification.
- (5) Remove nut (4) and washer (5) that secure terminal lugs (6) to bottom terminal of filter (7).
- (6) Remove two nuts (12), lock washers (9) and flat washers (13) that secure filter (7) to filter bracket (14).
- (7) Remove four nuts (15), lock washers (16), and flat washers (17) that secure filter (7) to front plate (2).
- (8) To replace filter (7) secure filter to front plate (2) with four nuts (15), lock washers (16), and flat washers (17).
- (9) Secure filter (7) to filter bracket (14) with two nuts (12), and lock washers (9) and flat washers (13).
- (10) Secure terminal lugs (6) to bottom terminal of filter (7) with nut (4) and washer (5) as tagged during removal. Also secure terminal lug (11) to center post of filter with flat washer (10), lock washer (9) and nut (8).
- (11) Carefully insert filters (7) and attached front plate (2) into filter chassis (3). Secure with 12 flat-head screws (1).
- (12) Refer to figure 5-3. Install RFI filter assembly (6) in accordance with paragraph 5-11a.
- (13) Refer to figure 5-3. Install bottom cover (3) in accordance with paragraph 5-11c.
- (14) Refer to section V of this chapter.

g. Filter FL6 Removal and Replacement. Refer to figure 5-4 unless otherwise indicated, proceed as follows:

- (1) Refer to figure 5-3. Remove bottom cover (3) in accordance with paragraph 5-10a.
- (2) Refer to figure 5-3. Remove the RFI filter (6) assembly in accordance with paragraph 5-10c, steps (1) through (4).

- (3) Remove 12 screws (1) from the filter-mounted side of the RFI filter assembly. Carefully lift RFI filter assembly front plate (2) to obtain access to filter FL6 (92).
- (4) Tag wires to filter FL6 for proper identification.
- (5) Unsolder both wires to the filter, then remove the nut (92A) and lock washer (92B) that secure FL6 (92) to the front plate (2), then remove the filter FL6.
- (6) To install a replacement FL6, secure it to the front plate with nut (92A) and lock washer (92B). Solder both wires to FL6.
- (7) Secure the front plate with 12 screws (1). Take care not to pinch wiring between cover and housing.
- (8) Refer to figure 5-3. Replace RFI filter assembly (6) in accordance with paragraph 5-11a, and bottom cover (3) in accordance with paragraph 5-11c.
- (9) Refer to section V of this chapter.

h. Bus Bar E12, E13, and E14 Removal and Replacement. Refer to figure 5-4 unless otherwise indicated and proceed as follows:

- (1) Refer to figure 5-3. Remove bottom cover (3) in accordance with paragraph 5-10a, then remove RFI filter assembly (6) in accordance with paragraph 5-10c, steps (1) through (4).
- (2) Remove 14 screws (96) that secure filter cover (78) to filter chassis.
- (3) Remove screws (27) that secure terminal lugs (28) to bus bar being removed.
- (4) Remove two flat-head screws (25) that secure the bus bar (26) to filter chassis (3). Remove bus bar.
- (5) To replace bus bar (26), secure bus bar to filter chassis (3) with two flat-head screws (25). Secure lugs (28) to bus bar with screw (27).
- (6) Refer to figure 5-3. Install RFI filter assembly (6) in accordance with paragraph 5-11a and bottom cover (3) in accordance with paragraph 5-11c.
- (7) Refer to section V of this chapter.

i. Connector J9, J10, and J11 Removal and Replacement. Refer to 5-4 unless otherwise indicated and proceed as follows:

- (1) Refer to figure 5-3. Remove bottom cover (3) in accordance with paragraph 5-10a, then remove RFI filter

assembly (6) from chassis in accordance with paragraph 5-10c, steps (1) through (4).

- (2) Remove 12 flat-head screws (18) from the connector-mounted side of the RFI filter chassis (3). Carefully pull connectors (24) and attached filter cover (19) from filter chassis.
- (3) Remove four screws (20), flat washer (21), lock washers (22), and nuts (23) that secure connector (24) to filter cover (19) and remove connector.
- (4) Properly tag wires for identification. Pull heatshrink tubing away from connector terminals and unsolder wires from connector.
- (5) To replace connector, insert connector through opening in filter cover (19) and secure with four screws (20), flat washers (21), lock washers (22), and nuts (23). Slide length of heatshrink tubing (items 7 through 11, App. D) over wires then solder wires as marked during removal. Slide heatshrink tubing over connection and shrink.
- (6) Secure filter cover (19) with attached connectors (24) to the side of RFI assembly with 12 flat-head screws (18).
- (7) Refer to figure 5-3. Install RFI filter assembly (6) in accordance with paragraph 5-11a and bottom cover (3) in accordance with paragraph 5-11c.
- (8) Refer to section V of this chapter.

j. Terminal Board TB2 and TB3 Removal and Replacement. Refer to figures 5-5 unless otherwise indicated and proceed as follows:

- (1) Refer to figure 5-3. Remove bottom cover (3) in accordance with paragraph 5-10a. Remove RFI filter assembly (6) in accordance with paragraph 5-10c, steps (1) through (4).
- (2) Tag for proper identification and remove wires and connecting links (61) from terminal board (58).
- (3) Refer to figure 5-3. Remove four nuts (55), lock washers (56), and flat washers (57) that secure terminal board (58) to component shelf (figure 5-3 (27)) and remove terminal board (58) and insulating strip (60).
- (4) To replace terminal board (58), place insulating strip (60) on terminal board. Secure terminal board to component shelf (27) with four flat washers (57), lock washers (56), and nuts (55).
- (5) Replace wires and connecting links (61) as marked during removal and remove tags.

(6) Refer to figure 5-3. Install RFI filter assembly (6) in the chassis in accordance with paragraph 5-11a and bottom cover (3) in accordance with paragraph 5-11c.

(7) Refer to section V of this chapter.

k. Terminal Board TB1 Removal and Replacement. Refer to figure 5-3 unless otherwise indicated and proceed as follows:

(1) Remove top cover (2) and bottom cover (3) in accordance with paragraph 5-10a.

(2) Remove high voltage shield (5) from the chassis in accordance with paragraph 5-10b.

(3) Remove RFI filter assembly (6) in accordance with paragraph 5-10c, steps (1) through (4).

(4) Remove four screws (59), eight flat washers (57), four lock washers (56), and nuts (55) that secure terminal board (58) to rear of chassis and remove terminal board (58).

(5) Refer to figure 5-5. Tag and remove wires and connecting links (61) from terminal board (58).

(6) Refer to figure 5-5. Replace wires and connecting links (61) as marked and remove tags.

(7) To replace terminal board (58) secure it to rear of chassis with four screws (59), eight flat washers (57), four lock washers (56), and nuts (55).

(8) Replace RFI filter assembly (6) in accordance with paragraph 5-11a.

(9) Install high voltage shield (5) in the chassis in accordance with paragraph 5-11b, and top cover (2) in accordance with paragraph 5-11c.

(10) Refer to section V of this chapter.

l. Insulating Strip Removal and Replacement. Refer to figure 5-3 and proceed as follows:

(1) Remove terminal board in accordance with paragraph 5-12j (TB2 and TB3) or 5-12k (TB1). Remove insulating strip (60).

(2) To replace insulating strip (60) place it beneath terminal board, then secure terminal board in accordance with paragraph 5-12j (TB2 or TB3) or 5-12k (TB1).

(3) Refer to section V of this chapter.

m. Connecting Link Removal and Replacement. Refer to figures 5-3 and 5-5 and proceed as follows:

- (1) Remove bottom cover (3) in accordance with paragraph 5-10a and/or high voltage shield (5) in accordance with paragraph 5-10b depending on location of connecting link being replaced.
- (2) Refer to figure 5-5. Remove connecting link (61) from terminal board (58).
- (3) To replace connecting link, position it on terminal board and secure in accordance with paragraph 5-12j (TB2 and TB3) or 5-12K (TB1).
- (4) Replace bottom cover (3) in accordance with paragraph 5-11c and/or high voltage shield (5) in accordance with paragraphs 5-11b.
- (5) Refer to section V of this chapter.

n. Component Shelf Removal and Replacement. Refer to figure 5-3 and proceed as follows:

- (1) Remove top cover (2) and bottom cover (3) in accordance with paragraph 5-10a.
- (2) Remove RFI filter assembly (6) from the chassis in accordance with paragraph 5-10c, steps (1) through (4) and high voltage shield (5) in accordance with paragraph 5-10b.
- (3) Remove relay K4(23) in accordance with paragraph 5-12c.
- (4) Remove relays K1, K2, and K3 (30) in accordance with paragraph 5-12e.
- (5) Remove socket XK4 (24) in accordance with paragraph 5-12d.
- (6) Remove terminal board TB2 and TB3 (58) in accordance with paragraphs 5-12j.
- (7) Remove insulating strip (60) in accordance with paragraph 5-12, step 1.
- (8) Remove eight screws (25), eight lock washers (26), and flat washers (26A) that secure component shelf (27) to the chassis.
- (9) To replace component shelf (27), secure it to chassis with eight screws (25), eight lock washers (26), and flat washers (26A).

- (10) Install insulating strip (60) in accordance with paragraph 5-12i.
 - (11) Install terminal board TB2 and TB3 (58) in accordance with paragraphs 5-12j.
 - (12) Install socket XK4 (24) in accordance with paragraph 5-12d and relay K4 (23) in accordance with paragraph 5-12c.
 - (13) Install relays K1, K2, and K3 (30) in accordance with paragraph 5-12e.
 - (14) Replace RFI filter assembly (6) in accordance with paragraph 5-11a and bottom cover (3) in accordance with paragraph 5-11c.
 - (15) Replace high voltage shield (5) in accordance with paragraph 5-11b and top cover (2) in accordance with paragraph 5-11c.
- o. Connector J1 through J8 Removal and Replacement. Refer to figure 5-3 and proceed as follows:
- (1) Remove top cover (2) and bottom cover (3) in accordance with paragraph 5-10a.
 - (2) Remove the high-voltage shield (5) in accordance with paragraph 5-10b.
 - (3) Remove four screws (36), flat washers (37), lock washers (38), and nuts (39) that secure connector (35) to chassis and remove connector.
 - (4) Pull heatshrink tubing away from connector terminals, tag and unsolder wires from connector.
 - (5) To replace connector, slide length of heatshrink tubing (items 7 through 11, App. D) over wires, then solder wires to connector terminals as marked during removal. Slide heatshrink tubing over connection and shrink.
 - (6) Insert connector through opening in chassis, and secure with four screws (36), flat washers (37), lock washers (38), and nuts (39).
 - (7) Install high-voltage shield (5) in accordance with paragraph 5-11b.
 - (8) Install top cover (2) and bottom cover (3) in accordance with paragraph 5-11c.
 - (9) Refer to section V of this chapter.

p. Lampholder XDSI Removal and Replacement. Refer to figure 5-3 and proceed as follows:

- (1) Remove the bottom cover (3) in accordance with paragraph 5-10a.
- (2) Pull heatshrink tubing away from lampholder (40) terminals, tag and unsolder wires from lampholder (40).
- (3) Remove nut (41) and washer (42) that secure lampholder (40) to front panel (16) and remove lampholder (40) from chassis.
- (4) To replace lampholder (40), insert lampholder through opening in front panel (16) and secure with nut (41) and washer (42).
- (5) Solder wires as marked during removal. Slide heatshrink tubing (item 10, App. D) over connections and remove tags from wires.
- (6) Install bottom cover (3) in accordance with paragraph 5-11c.
- (7) Refer to section V of this chapter.

q. Handle Removal and Replacement. Refer to figure 5-3 and proceed as follows:

- (1) Remove top cover (2) and bottom cover (3) in accordance with paragraph 5-10a.

NOTE

It may be necessary to remove circuit breaker CB8 in order to obtain access to attaching parts for handle. (Refer to paragraph 5-12b.)

- (2) Remove two screws (48), lock washers (49), and flat washers (50) that secure handle (51) to front panel (16).
- (3) To replace handle (51), secure to front panel (16) with two screws (48), lock washers (49), and flat washers (50).
- (4) Install top cover (2) and bottom cover (3) in accordance with paragraph 5-11c.

r. Front Panel Removal and Replacement. Refer to figure 5-3 and proceed as follows:

- (1) Remove top cover (2) and bottom cover (3) in accordance with paragraph 5-10a.

NOTE

It may be necessary to remove the RFI filter assembly (6) in order to obtain access to attaching parts for front panel. (Refer to paragraph 5-10c, steps (1) through (4).)

- (2) Remove MISSION POWER switch S1 (13) in accordance with paragraph 5-12a.
- (3) Remove circuit breakers (18) in accordance with paragraph 5-12b.
- (4) Remove lampholder XDSI (40) in accordance with paragraph 5-12p.
- (5) Remove handles (51) in accordance with paragraph 5-12q.
- (6) Using thin-walled socket tool TMD-16 and 1/4 inch drive wrench remove 14 nuts (52), lock washers (53), and flat washers (54) from stud (65) on rear of front panel (16) and remove front panel (16) from chassis.
- (7) To replace front panel (16), place front panel (16) on chassis and using thin-walled socket tool TMD-16 and 1/4 inch drive wrench, thread 14 nuts (52), lock washers (53), and flat washers (54) on stud (65) at rear of panel.
- (8) Install handles (51) on front panel (16) in accordance with paragraph 5-12q.
- (9) Install lampholder XDSI (40) on front panel (16) in accordance with paragraph 5-12p.
- (10) Install circuit breakers (18) on front panel (16) in accordance with paragraph 5-12b.
- (11) Install MISSION POWER switch SI (13) in accordance with paragraph 5-12a.
- (12) Replace top cover (2) and bottom cover (3) in accordance with paragraph 5-11c.
- (13) Refer to section V of this chapter.

s. Riveting Removal and Replacement. To replace a rivet(s) on the chassis or on an item of hardware, proceed as follows:

- (1) Remove covers and components as required to gain access to rivet(s) to be replaced. (Refer to paragraph 5-10.)
- (2) Center punch the head of rivet(s) to be replaced.
- (3) Using a drill smaller than the diameter of the rivet, drill out the center of rivet head to be replaced.

- (4) Increase the size of the drill to rivet size or a size slightly smaller than rivet size, and again drill out rivet head. Rivet head should fall off at this point. If not, position a punch or similar tool against the rivet head and carefully drive it out with a hammer.
- (5) Using a punch and a hammer, punch out the remainder of the rivet(s) to be replaced.
- (6) Obtain replacement part or item of hardware and mount in correct position.
- (7) Obtain and install appropriate size rivet. Using the riveter and appropriate size head, install the replacement rivet(s).
- (8) Replace cover and components in accordance with paragraph 5-11.

t. Cable Mount and Grommet Repair. To replace a cable mount or plastic grommet, proceed as follows:

- (1) Remove cover and/or components in accordance with procedures in paragraph 5-10 to obtain access to area where repair is to occur.

WARNING

Adequate ventilation must be provided while using trichlorotrifluoroethane. Prolonged breathing of vapor should be avoided. The solvent must not be used near heat or open flame; the products of decomposition are toxic and irritating. Since trichlorotrifluoroethane dissolves natural oils, prolonged contact with skin should be avoided. When necessary, use heavy duty rubber gloves (item 6, App. D) that the solvent cannot penetrate. If the solvent is taken internally, consult a physician immediately.

- (2) Remove old adhesive using cloth dampened (not wet) with trichlorotrifluoroethane (item 13, App. D).
- (3) After one minute drying time, apply coating of clear adhesive, type 608 (item 1, App. D) to surface where part is to be mounted, then press part into adhesive and allow to dry for at least one minute.

u. Identification Plate Removal and Replacement. To remove and replace the identification plate refer to figure 5-3 and proceed as follows:

- (1) Remove bottom cover (3) in accordance with paragraph 5-10a.

- (2) Remove two screws (43), four flat washers (44), two lock washers (45) and two nuts (46) that secure identification plate (47) to the front panel.
- (3) To replace the identification plate (47), secure it to front panel with two screws (43), four flat washers (44), two lock washers (45), and two nuts (46).
- (4) Replace bottom cover (3) in accordance with paragraph 5-11c.

v. Externally Relieved (Captive) Screw Removal and Replacement. To remove and replace captive screws/threaded inserts, proceed as follows:

- (1) Refer to figure 5-3. Carefully back (unscrew) captive screw (16A) out of threaded insert (16B).
- (2) Drill out threaded insert using a drill bit as close in diameter to insert as possible, but not larger than diameter of insert. Remove threaded insert from panel.
- (3) Install new threaded insert into hole on front panel, then swage insert from back side of panel to secure it in hole.
- (4) Replace captive screw into threaded insert.

w. Shield Gasket Removal and Replacement. To remove and replace the EMI shield gasket on the front panel, proceed as follows:

- (1) Refer to figure 5-3. Form and cut a new gasket (item 5, App. D) using damaged one still mounted to back of panel as a guide. Also mark new gasket for hole placement and drill out holes.
- (2) Remove damaged gasket using a knife or other sharp instrument.

WARNING

Adequate ventilation must be provided while using trichlorotrifluoroethane. Prolonged breathing of vapor should be avoided. The solvent must not be used near heat or open flame; the products of decomposition are toxic and irritating. Since trichlorotrifluoroethane dissolves natural oils, prolonged contact with skin should be avoided. When necessary, use gloves (item 6, App. D) that the solvent cannot penetrate. If the solvent is taken internally, consult a physician immediately.

- (3) Remove old adhesive and gasket residue using cloth dampened (not wet) with trichlorotrifluoroethane (item 13, App. D).
- (4) After panel surface is dry, apply MA-509A silicone compound (item 3, App. D) to new gasket, then place new gasket on back of panel and press into place. Allow one minute drying time for compound before replacing front panel.

x. Access Cover Repair. The access cover (figure 5-3, item (2) and (3)) is repairable by removing and replacing the shielding gasket (1B), gasket retainer (1C) or panel screw (1). To repair a top or bottom access cover, proceed as follows:

- (1) If a rivet (1A) comes loose or is damaged, replace the rivet in accordance with paragraph 5-12s.
- (2) If the shielding gasket (1B) becomes defective, follow procedures given to remove rivets in paragraph 5-12s, steps (1) through (5). Remove 20 rivets that secure gasket retainer (1C) and shielding gasket to access cover.
- (3) If the shielding gasket becomes defective, the 20 panel screws (1) must be removed before the gasket can be removed. Use pair of side-cut pliers or dikes to cut off threaded portion of panel screw, then remove screws, retainer and gasket.
- (4) Use a drill bit with a diameter as close as possible to that of the panel screw sleeve, but not larger than the inner diameter of the sleeve, to drill out the sleeves still in the panel.
- (5) Use damaged gasket as a pattern to form a new gasket and to mark new gasket for correct hole positions. Solder gasket where two ends join together.
- (6) Use gasket retainer to overlay onto gasket and drill 20 - 0.095 inch diameter holes through gasket for new rivets. Also drill 20 - 0.187 (+.004 - 001) inch diameter holes through gasket for new panel screws.
- (7) Place gasket retainer on top of gasket, then place both on bottom of access cover and align holes. Using an H7503-X installation tool, install 20 new panel screws and sleeves.
- (8) Install 20 new rivets in accordance with paragraph 5-12s, steps (6) and (7).
- (9) If a panel screw becomes damaged, replace it in accordance with step (3), (4) and (7) of this procedure.

- (10) If a gasket retainer becomes damaged, replace it in accordance with steps (1) through (4), (7) and (8) of this procedure.

y. RFI Filter Chassis Repair. The RFI filter chassis (figure 5-3, item 6) is repairable by removing and replacing a defective helicoil insert (90) (figure 5-4). To repair the RFI filter chassis, proceed as follows:

- (1) Refer to figures 5-4 and 5-7. Insert blade of helicoil extracting tool (item a, figure 5-7) into insert so that flat side of blade faces top of insert. (Blade is perpendicular to tang break-off point.)
- (2) Strike head of extracting tool with a light blow so that blade cuts into damaged insert slightly.
- (3) Maintain steady pressure between blade and insert while unscrewing insert out of chassis.
- (4) Thread replacement helicoil onto mandril of installation tool (item b, figure 5-7). Screw insert into hole to depth of one-half turn below surface of chassis.
- (5) Insert end of tang break-off tool (item c, figure 5-7) into insert and apply pressure. The spring-loaded punch mechanism within tang break-off tool will provide a sharp blow to break tang.
- (6) Remove tang from hole.

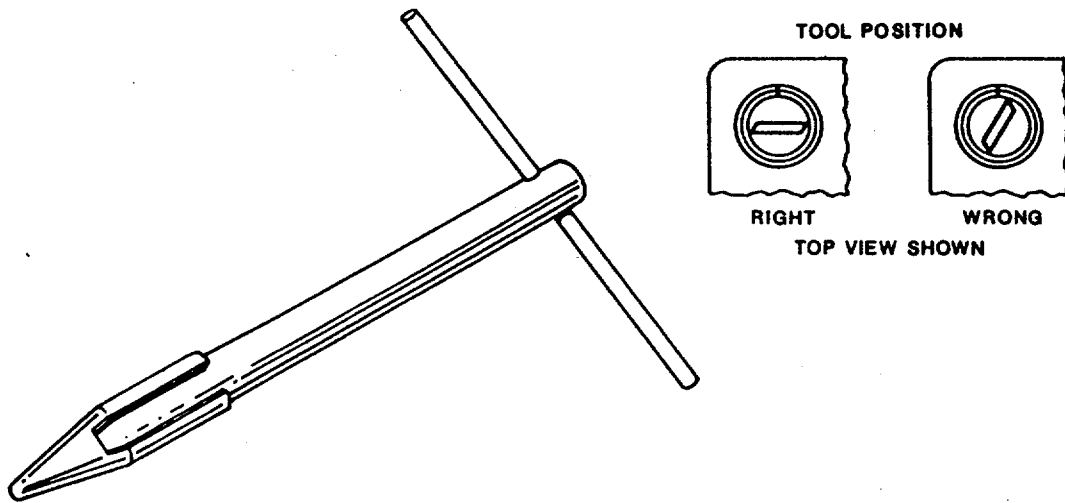

(a) Extracting Tool, Part No. 1227-06



(b) Hand Inserting Tool, Part No. 7551-04

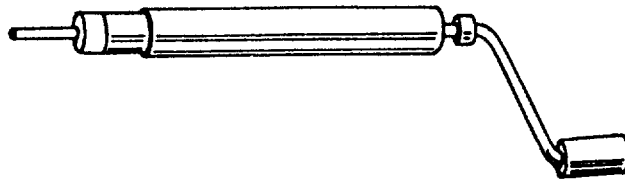

(c) Tang Break-off Tool, Part No. 3695-04

Figure 5-7. Threaded Insert Removal and Replacement Tools

SECTION V. GENERAL SUPPORT TEST PROCEDURE

5-13. General. This section provides the test procedure to determine whether the performance of the repaired power distribution box is satisfactory for return to the user.

5-14. Test. Perform all the steps in table 5-4 to verify operation of the power distribution box. Perform each step in the sequence listed.

5-39/(5-40 blank)

APPENDIX A

REFERENCES

A-1. Scope.

This appendix lists all technical manuals, miscellaneous publications, regulations, and forms referenced in this manual or pertaining to Distribution Box J-3986/ALQ-151(V).

A-2. Technical Manuals.

<u>Publication number</u>	<u>Title</u>
TM 11-5821-262-20	Organizational Maintenance Manual, Communications System Control C-6533()/ARC
TM 32-5865-012-10	Operation Instructions, Special Purpose Countermeasures System AN/ALQ-151(V)2
TM 32-5865-012-20	Maintenance Instructions, Organizational, Special Purpose Countermeasures System AN/ALO-151(V)2
TM 38-230-1	Packaging of Material: Preservation
TM 38-230-2	Packaging of Material: Packing
TM 38-260	Preparation of Industrial Plant Equipment for Storage or Shipment
TM 43-0139	Painting Instructions for Field Use
TM 740-90-1	Administrative Storage of Equipment
TM 750-244-2	Procedures for Destruction of Electronics Materiel to Prevent Enemy Use (Electronics Command)
TB 43-0118	Field Instructions for Painting and Preserving Electronics Command Equipment Including Camouflage Pattern Painting of Electrical Equipment Shelters

A-3. Supply Bulletins.

<u>Publication number</u>	<u>Title</u>
SB 11-573	Painting and Preservation Supplies Available for Field Use for Electronics Command Equipment
SB 38-100	Preservation, Packaging and Packing Materials, Supplies and Equipment Used by the Army

A-4. Common Table of Allowances.

<u>Publication number</u>	<u>Title</u>
CTA 50-970	Expendable Items

A-5. Pamphlets.

<u>Publication number</u>	<u>Title</u>
DA PAM 310-1	Index of Administrative Publications
DA PAM 310-2	Index of Blank Forms
DA PAM 310-2	Index of Technical Manuals; Technical Bulletins, Supply Manuals (Types 7, 8, 9), Supply Bulletins, and Lubrication Orders
DA PAM 738-750	The Army Maintenance Management System (TAMMS)

A-6. Army Regulations.

<u>Publication number</u>	<u>Title</u>
AR 310-25	Dictionary of United States Army Terms
AR 310-50	Catalog of Abbreviations and Brevity Codes
AR 55-38	Reporting of Transportation Discrepancies in Shipments

A-7. Forms.

<u>Publication number</u>	<u>Title</u>
DA Form 2028 Publications and Blank Forms	Recommended Changes to
DA Form 2404 Work Sheets	Equipment Inspection and Maintenance
DA Form 2407	Maintenance Request
DA Form 2408	Equipment Log Assembly (Records)
DA Form 2408-1	Equipment Daily Log
DA Form 2408-5	Equipment Modification Record
SF 361	Discrepancy in Shipment Report
SF 364	Report of Discrepancy
SF 368	Quality Deficiency Report

A-3/(A-4 blank)

APPENDIX B MAINTENANCE ALLOCATION CHART

SECTION I. INTRODUCTION

B-1. General.

a. The maintenance allocation chart identifies the maintenance operations that must be performed. It assigns each of those operations to the lowest level of maintenance authorized to perform the complete task, or any part of the task, in terms of availability of time, tools, test and support equipment, skills and employment of the subsystem.

b. The Maintenance Allocation Chart (MAC) in Section II designates overall responsibility for the performance of maintenance functions for the Distribution Box J-3986/ALQ-151(V).

c. Section III lists the special tools and test equipment required for each maintenance function as referenced from Section II.

d. Section IV contains supplemental instructions on explanatory notes for a particular maintenance function.

B-2. Maintenance Functions.

a. Inspect. To determine the serviceability of an item by comparing its physical, mechanical and/or electrical characteristics with established standards through examination.

b. Test. To verify serviceability and detect incipient failure by measuring the mechanical or electrical characteristics of an item And comparing those characteristics with prescribed standards.

c. Service. Operations required periodically to keep an item in proper operating condition; i.e., to clean (decontaminate), preserve, drain, paint or replenish fuel, lubricants, hydraulic fluids, or compressed air supplied.

d. Adjust. To maintain, within prescribed limits, by bringing into proper or exact position, or by setting the operating characteristics to specified parameters.

e. Align. To adjust specified variable elements of an item to bring about optimum or desired performance.

f. Calibrate. To determine and cause corrections to be made or to be adjusted on instruments or test, measuring and diagnostic equipments used in precision measurement. Consists of comparisons of two instruments, one of which is a certified standard of known accuracy; to detect and adjust any discrepancy in the accuracy of the instrument being compared.

g. Install. The act of emplacing, seating, or fixing into position an item, part, or module (component or assembly) in a manner to allow the proper functioning of an equipment or system.

h. Replace. The act of substituting a serviceable like type part, subassembly, or module (component or assembly) for an unserviceable counterpart.

i. Repair. The application of maintenance services¹ or other maintenance actions² to restore serviceability to an item by correcting specific damage, fault, malfunction, or failure in a part, subassembly, module (component or assembly), and items, or system.

j. Overhaul. The maintenance effort (services/actions) necessary to restore an item to a completely serviceable/operational condition as prescribed by maintenance standards (i.e., DMWR) in appropriate technical publication. Overhaul is normally the highest degree of maintenance performed by the Army. Overhaul does not normally return an item to like new condition.

k. Rebuild. Consists of those services/actions necessary for the restoration of unserviceable equipment to a like new condition in accordance with original manufacturing standards. Rebuild is the highest degree of material maintenance applied to Army equipment. The rebuild operation includes the act of returning to zero those age measurements (hours/miles, etc.) considered in classifying Army equipments/components.

B-3. Column Entries Used in the MAC.

a. Column 1, Group Number. Column 1 list group numbers, the purpose of which is to identify components, assemblies, subassemblies, and modules with the next higher assembly.

b. Column 2, Component/Assembly. Column 2 contains the names of components, assemblies, subassemblies, and modules for which maintenance is authorized.

c. Column 3, Maintenance Functions. Column 3 lists the functions to be performed on the item listed in column 2. (For detailed explanation of these functions, see para. B-2).

d. Column 4, Maintenance Category.

(1) Column 4 specifies, by the listing of a "work time" figure in the appropriate sub-column(s), the lowest level of

¹Services - inspect, test, service, adjust, align, calibrate, or replace.

²Action - welding, grinding, riveting, straightening, facing, remachining, or resurfacing.

maintenance authorized to perform the function listed in column 3. This figure represents the active time required to perform the maintenance function, at the indicated level of maintenance.

(2) If the number or complexity of the tasks within the listed maintenance function vary at different maintenance, appropriate "work time" figures will be shown for each level. The number of man-hours specified by the "work time" figure represents the average time required to restore an item (assembly, subassembly, component, module, end item, or system) to a serviceable condition under typical field operating conditions. This time includes preparation time, troubleshooting time, and quality assurance/quality control time in addition to the time required to perform the specific tasks identified for the maintenance functions authorized in the maintenance allocation chart. The symbol designations for the various maintenance levels are as follows:

- C - Operator or crew.
- O - Organizational maintenance.
- F - Direct support maintenance.
- H - General support maintenance.
- D - Depot maintenance.

e. Column 5, Tools and Equipment. Column 5 specifies, by code, those common tool sets (not individual tools) and special tools, test, and support equipment required to perform the designated function.

f. Column 6, Remarks. Column 6 contains a letter code in alphabetical order which is keyed to the remarks contained in Section IV. If no remarks were necessary, the column remains blank and Section IV is deleted.

B-4. Column Entries Used in Tool and Test Equipment Requirements (Section III).

a. Column 1, Tool or Test Equipment Reference Code. The tool and test equipment reference code correlates with a maintenance function on the identified end item or component.

b. Column 2, Maintenance Category. The lowest level of maintenance authorized to use the tool or test equipment.

c. Column 3, Nomenclature. Name or identification of the tool or test equipment.

d. Column 4, National/NATO Stock Number. The National or NATO stock number of tool or test equipment.

e. Column 5, Tool Number. The manufacturer's part number.

B-5. Explanation of Columns in Section IV.

a. Reference Code. The code scheme recorded in Column 1, Section III.

b. Remarks. This column lists information pertinent to the maintenance function being performed as indicated on the MAC, Section II. If no remarks were necessary the section is deleted.

SECTION II.

TABLE B-1. MAINTENANCE ALLOCATION CHART FOR DISTRIBUTION BOX J-3986/ALQ-151(V)

(1) GROUP NUMBER	(2) COMPONENT/ASSEMBLY	(3) MAINTENANCE FUNCTION	(4) MAINTENANCE CATEGORY					(5) TOOLS AND EQUIPMENT	(6) REMARKS
			C	O	F	H	D		
40	DISTRIBUTION BOX AS	Inspect Test Service Repair				0.1 0.2 0.2 0.4		13 4,9,10,11, 13,15,16 7,13 4,7,8,9,10 11,13,14, 15,16	
4001	PANEL ASSEMBLY, FRON	Inspect Replace Repair				0.1 0.3 0.5		13 12,13 13	
4002	CHASSIS ASSEMBLY, EL	Inspect Replace Repair				0.1 1.0 0.2		13 6,12,13 13	
4003	COVER, ACCESS	Inspect Replace Repair				0.1 0.1 0.8		13 5,6,12,13 13	
4004	FILTER ASSEMBLY, RAD	Inspect Replace Repair				0.1 0.3 0.5		13 1,2,3,8,13 8,13	
4005	COVER, ACCESS	Inspect Replace Repair				0.1 0.1 0.8		13 5,12,13 13	

**SECTION III. TABLE B-2. TOOL AND TEST EQUIPMENT REQUIREMENTS FOR
DISTRIBUTION BOX J-3986/ALQ-151(V)**

TOOL OR TEST EQUIPMENT REF CODE	MAINTENANCE CATEGORY	NOMENCLATURE	NATIONAL/NATO STOCK NUMBER	TOOL NUMBER
1	H	INSERT EXTRACTION	5120-00-793-1073	1227-06
2	H	TANG BREAK	5120-00-816-5703	3695-04
3	H	INSERT INSTALLATION	- - -	7551-04
4	H	MULTIMETER, DIGITAL	6625-01-139-2512	AN/PSM-45
5	H	HAND INSTALLATION TOOL	- - -	H7503-X
6	H	RIVETER KIT	6625-01-022-4165	HP-200
7	H	MAINT KIT ELECTRONIC	6625-01-068-1665	MK-1961/G
8	H	MAINT KIT ELECTRONIC	6625-01-068-1666	MK-1962/G
9	H	CONNECTOR ASSY P2	- - -	P2 (REF APP E)
10	H	CONNECTOR ASSY P8	- - -	P8 (REF APP E)
11	H	POWER SUPPLY	- - -	PP-7546/U
12	H	TOOL KIT, ELEC EQUIP	5180-00-605-0079	TK-100/G
13	H	TOOL KIT, ELEC EQUIP	5180-00-610-8177	TK-105/G
14	H	THIN-WALL SOCKET TOOL	- - -	TMD-16
15	H	TEST CABLE W1	- - -	W1 (REF APP E)
16	H	TEST CABLE W2	- - -	W2 (REF APP E)

**APPENDIX C
REPAIR PARTS AND SPECIAL TOOLS LIST
FOR
DISTRIBUTION BOX J-3986/ALQ-151(V)**

TABLE OF CONTENTS

		Page	Illus Figure
Section	I Introduction.....	C-3	
	II Repair Parts List.....	C-10	
Group	40 Distribution Box J-3986/ ALQ-151(V).....	C-10	C-1
Section	III Special Tools List (not applicable).....	C-16	
	IV National Stock Number and Part Number Index	C-17	

C-1/(C-2 blank)

SECTION I. INTRODUCTION

C-1. Scope. This appendix lists spares and repair parts; special tools; special test, measurement, and diagnostic equipment (TMDE); and other special support equipment required for performance of direct support maintenance of the Distribution Box J-3986/ALQ-151(V). It authorizes the requisitioning and issue of spares and repair parts as indicated by the source and maintenance codes.

C-2. General. This repair parts and special tools list is divided into the following sections.

a. Section II. Repair Parts List. A list of spares and repair parts authorized for use in the performance of maintenance. The list also includes parts that must be removed for replacement of the authorized parts. Parts lists are composed of functional groups in numerical sequence, with the parts in each group listed in figure and item number sequence.

b. Section III. Special Tools List. Not applicable.

c. Section IV. National Stock Number and Part Number Index. A list, in national item identification number (NIIN) sequence, of all national stock numbers (NSNs) appearing in the listings, followed by a list, in alphabetical sequence, of all part numbers appearing in the listings. National stock numbers and part numbers are cross-referenced to each illustration figure and item number appearance.

C-3. Explanation of Columns.

a. Illustration. This column is divided as follows:

(1) Figure Number. Indicates the figure number of the illustration on which item is shown.

(2) Item Number. The number used to identify item called out in the illustration.

b. Source, Maintenance, and Recoverability (SMR) Codes.

(1) Source Code. Source codes indicate the manner of acquiring support items for maintenance, repair, or overhaul of end items. Source codes are entered in the first and second positions of the Uniform SMR Code format as follows:

<u>Code</u>	<u>Definition</u>
PA	- Item procured and stocked for anticipated or known usage.
PB	- Item procured and stocked for insurance purpose because essentially dictates that a minimum quantity be available in the supply system.
PC	- Item procured and stocked and which otherwise would be coded PA except that it is deteriorative in nature.
PD	- Support item, excluding support equipment, procured for initial issue or outfitting and stocked only for subsequent or additional initial issues of outfittings. Not subject to automatic replenishment.
PE	- Support equipment procured and stocked for initial issue or outfitting to specified maintenance repair activities.
PF	- Support equipment that will not be stocked but will be centrally procured on demand.
PG	- Item procured and stocked to provide for sustained support for the life of the equipment. It is applied to an item peculiar to the equipment which, because of probable discontinuance or shutdown of production facilities, would prove uneconomical to produce at a later time.
KD	- An item of a depot overhaul/repair kit and not purchased separately. Depot kit defined as a kit that provides items required at the time of overhaul or repair.
KF	- An item of a maintenance kit and not purchased separately. Maintenance kit defined as a kit that provides an item that can be replaced at organizational or intermediate levels of maintenance.
KB	- Item included in both a depot overhaul/repair kit and a maintenance kit.
MO	- Item to be manufactured or fabricated at organizational level.
MF	- Item to be manufactured or fabricated at the direct support maintenance level.
MH	- Item to be manufactured or fabricated at the general support maintenance level.

<u>Code</u>	<u>Definition</u>
MD	- Item to be manufactured or fabricated at the depot maintenance level.
AO	- Item to be assembled at the organizational level.
AF	- Item to be assembled at the direct support maintenance level.
AH	- Item to be assembled at the general support maintenance level.
AD	- Item to be assembled at the depot maintenance level.
XA	- Item is not procured or stocked because the requirements for the item will result in the replacement of the next higher assembly.
XB	- Item is not procured or stocked. If not available through salvage, requisition.
XC	- Installation drawing, diagram, instruction sheet, or field service drawing that is identified by manufacturer's part number.
XD	- A support item that is not stocked. When required, item will be procured through normal supply channels.

NOTE

Cannibalization or salvage may be used as a source of supply for any items coded above except those coded XA and aircraft support items as restricted by AR 700-42.

(2) *Maintenance Code.* Maintenance codes are assigned to indicate the levels of maintenance authorized to USE and REPAIR support items. The maintenance codes are entered in the third and fourth positions of the Uniform SMR Code format as follows:

(a) The maintenance code entered in the third position will indicate the lowest maintenance level authorized to remove, replace, and use the support item. The maintenance code entered in the third position will indicate one of the following levels of maintenance:

<u>Code</u>	<u>Application/Explanation</u>
C	- Crew or operator maintenance performed within organizational maintenance.
O	- Support item is removed, replaced, used at the organizational level.
F	- Support item is removed, replaced, used at the direct support level.
H	- Support item' is removed, replace, used at the general support level.
D	- Support item is removed, replaced, used at depot, mobile depot, or specialized repair activity only.

(b) The maintenance code entered in the fourth position indicates whether the item is to be repaired and identifies the lowest maintenance level with the capability to perform complete repair (i.e., all authorized maintenance functions). This position will contain one of the following maintenance codes:

<u>Code</u>	<u>Application/Explanation</u>
O	- The lowest maintenance level capable of complete repair of the support item is the organizational level.
F	- The lowest maintenance level capable of complete repair of the support item is the direct support level.
H	- The lowest maintenance level capable of complete repair of the support item is the general support level.
D	- The lowest maintenance level capable of complete repair of the support item is the depot level.
L	- Repair restricted to (enter applicable designated specialized repair activity) specialized repair activity.
Z	- Nonreparable. No repair is authorized.
B	- No repair is authorized. The item may be reconditioned by adjusting, lubricating, etc., at the user level. No parts or special tools are procured for the maintenance of this item.

(3) Recoverability Code. Recoverability codes are assigned to support items to indicate the disposition action on unserviceable items. The recoverability code is entered in the fifth position of the Uniform SMR Code format as follows:

<u>Recoverabil- ity Codes</u>	<u>Definition</u>
Z - position 3.	Nonreparable item. When unserviceable, condemn and dispose at the level indicated in position 3.
O - level.	Reparable item. When uneconomically reparable, condemn and dispose at organizational level.
F - support level.	Reparable item. When uneconomically reparable, condemn and dispose at the direct support level.
H - support level.	Reparable item. When uneconomically reparable, condemn and dispose at the general support level.
D -	Reparable item. When beyond lower level repair capability, return to depot. Condemnation and disposal not authorized below depot level.
L -	Reparable item. Repair, condemnation, and disposal not authorized below depot/specialized repair activity level.
A -	Item requires special handling or condemnation procedures because of specific reasons (i.e., precious metal content, high dollar value, critical material or hazardous material). Refer to appropriate manuals/directives for specific instructions.

c. National Stock Number. Indicates the national stock number assigned to the item and will be used for requisitioning.

d. Part Number. Indicates the primary number used by the manufacturer (individual, company, firm, corporation, or government activity), which controls the design and characteristics of the item by means of its engineering drawings, specifications, standards, and inspection requirements to identify an item or range of items.

NOTE

When a stock-numbered item is requisitioned, the item received may have a different part number than the part being replaced.

e. Federal Supply Code for Manufacturer (FSCM). The FSCM is a five-digit numeric code listed in SB 708-42 which is used to identify the manufacturer, distributor, or government agency, etc.

f. Description. Indicates the Federal item name and, if required, a minimum description to identify the item.

g. Unit of Measure (U/M). Indicates the standard of the basic quantity of the listed item as used in performing the actual maintenance function. This measure is expressed by a two-character alphabetical abbreviation (e.g., ea, in, pr, etc.). When the unit of measure differs from the unit of issue, the lowest unit of issue that will satisfy the required units of measure will be requisitioned.

h. Quantity Incorporated in Unit. Indicates the quantity of the item used in the breakout shown on the illustration figure, which is prepared for a functional group, subfunctional group, or an assembly.

C-4. Special Information. Not applicable.

C-5. How to Locate Repair Parts.

a. When National Stock Number or Part Number Is Unknown.

(1) *First*. Using the table of contents, determine the functional group within which the item belongs. This is necessary since illustrations are prepared for functional groups and listings are divided into the same groups.

(2) *Second*. Find the illustration covering the functional group to which the item belongs.

(3) *Third*. Identify the item on the illustration and note the illustration figure and item number of the item.

(4) *Fourth*. Using the repair parts list, find the figure and item number noted on the illustration.

b. When National Stock Number or Part Number is Known.

(1) *First*. Using the index of NSNs and Part Numbers, find the pertinent national stock number or part number. This index is in NIIN sequence followed by a list of part numbers in alphamerical sequence, cross-referenced to the illustration figure number and item number.

(2) *Second.* After finding the figure and item number, locate the figure and item number in the repair parts list.

C-6. Abbreviations. Not applicable.

SECTION II. REPAIR PARTS LIST

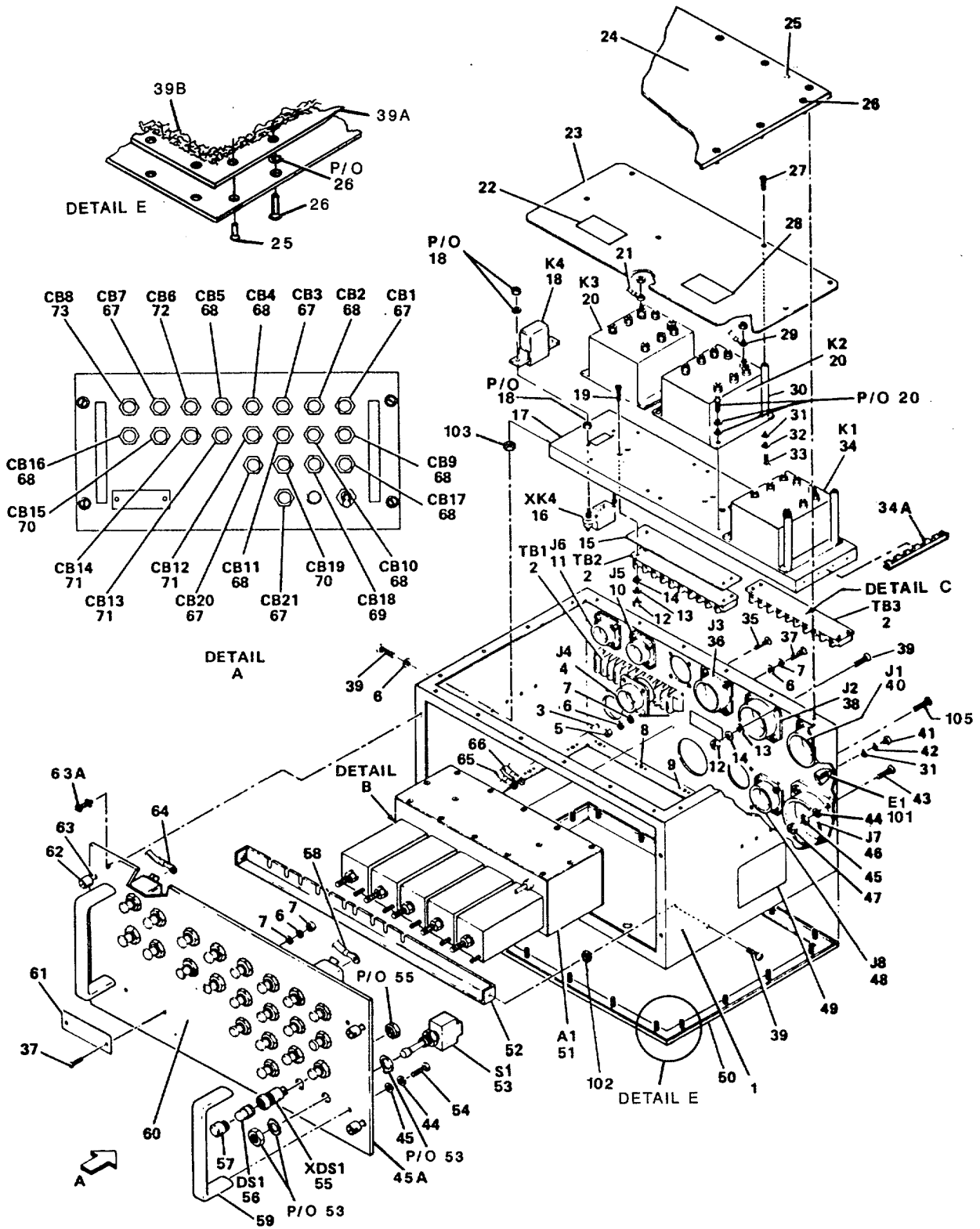

Figure C-1. Distribution Box J-3986/ALO-151(V) (Sheet 1 of 3)

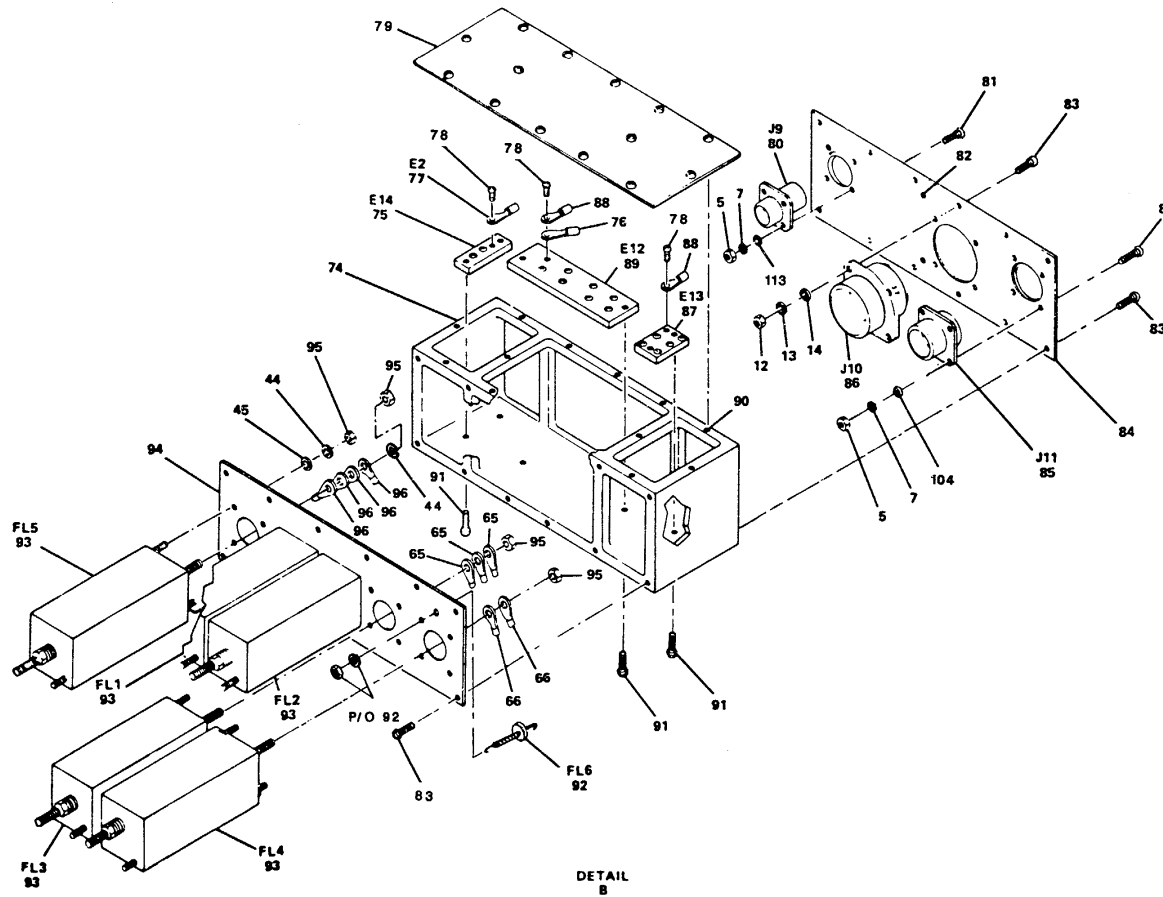

Figure C-1. Distribution Box J-3986/ALQ-151(V) (Sheet 2 of 3)

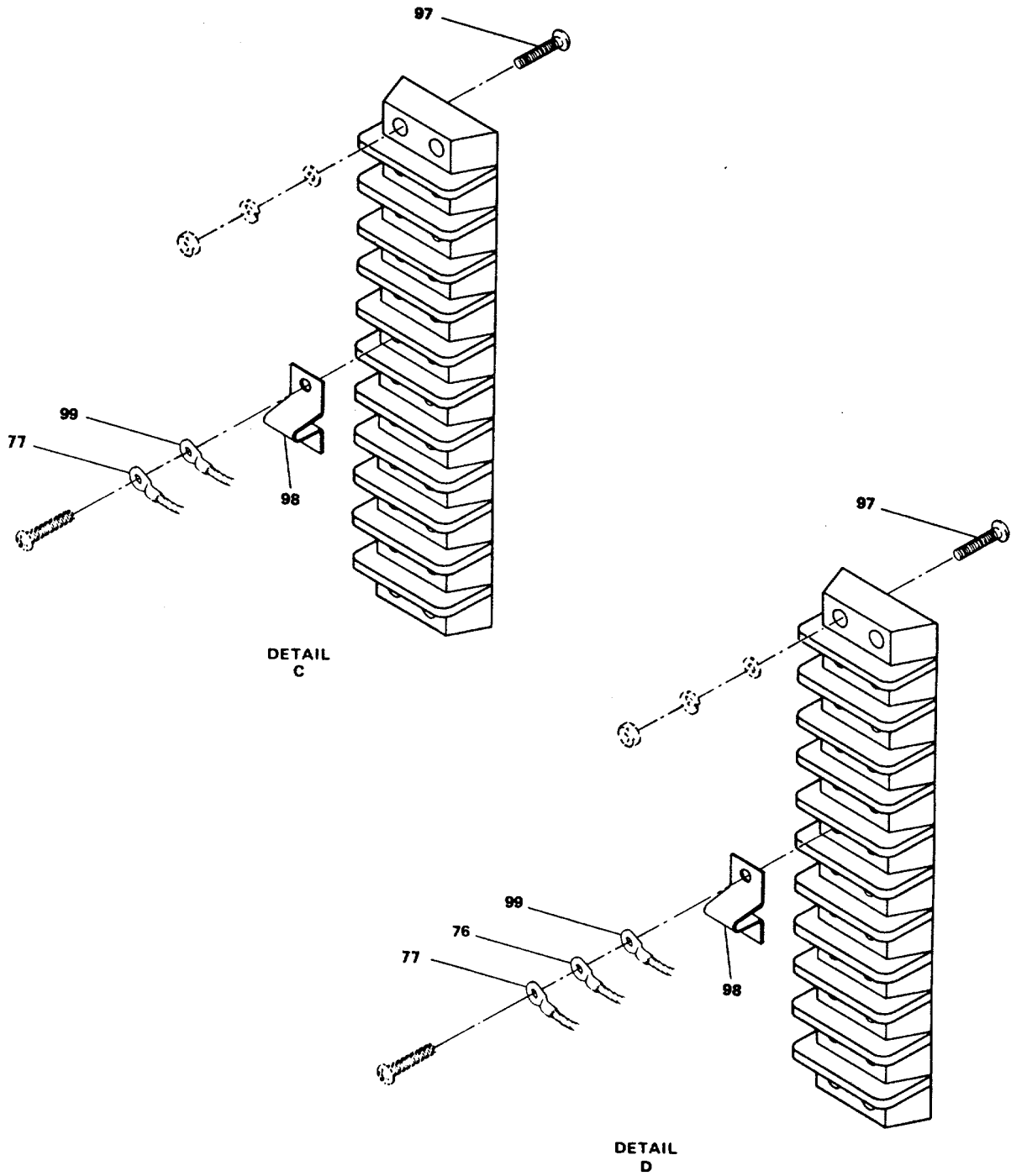

Figure C-1. Distribution Box J-3986/ALQ-151(V) (Sheet 3 of 3)

(1) ILLUSTRATION		(2)	(3)	(4)	(5)	(6)	(7)	(8)
(a) FIG NO.	(b) ITEM NO.	SMR CODE	NATIONAL STOCK NUMBER	PART NUMBER	FSCM	DESCRIPTION USABLE ON CODE	U/M	QTY INC IN UNIT
						GROUP 40-DISTRIBUTION BOX C5074236-1 (57958)		
C-1		XDHHH		C5074580-1	57958	CHASSIS ASSY, ELECT	EA	1
C-1	2	XDHZZ	5940-00-983-6087	38TB10	81349	TERMINAL BOARD	EA	3
C-1	3	XDHHZ		12-133295-1	28815	RCPT, GUIDE PIN	EA	2
C-1	4	PAHZZ	5935-00-846-2176	MS3112E20-16S	96906	CONN, RCPT, ELEC	EA	1
C-1	5	XDHZZ	5310-00-208-3786	NAS671C4	80205	NUT, PLAIN, HEX	EA	44
C-1	6	XDHZZ	5310-00-595-6211	MS15795-803	96906	WASHER, FLAT	EA	52
C-1	7	XDHZZ	5310-00-933-8118	MS35338-135	96906	WASHER, LOCK	EA	50
C-1	8	XDHZZ	5310-00-881-9981	NAS1068CO4M	80205	NUT, SLFLKG, PL	EA	40
C-1	9	XDHZZ	5320-00-117-6010	MS20426AD2-3	96906	RIVET, SOLID	EA	80
C-1	10	PAHZZ	5935-00-827-1545	MS3112E16-26S	96906	CONN, RCPT, ELEC	EA	1
C-1	11	PAHZZ	5935-00-836-0082	MS3112E16-8S	96906	CONN, RCPT, ELEC	EA	1
C-1	12	XDHZZ	5310-00-208-3786	NAS671C6	80205	NUT, PLAIN, HEX	EA	24
C-1	13	XDHZZ	5310-00-929-6395	MS35338-136	96906	WASHER, LOCK	EA	24
C-1	14	XDHZZ	5310-00-722-5998	MS15795-805	96906	WASHER, FLAT	EA	28
C-1	15	XDHZZ		MS601-10-GEE-1A	75382	INSUL, STRIP	EA	3
C-1	16	XDHZZ	5935-01-080-5000	S0-1049-8772	35344	SKT, ELEC COMPNT	EA	1
C-1	17	XDHHH		5065668-1	57958	SHELF ASSY, COMPONENT	EA	1
C-1	18	PAHZZ	5945-01-044-4645	MS27401-16	96906	RELAY, EM	EA	1
C-1	19	XDHZZ	5305-00-054-6656	MS51957-32	96906	SCREW, MACHINE	EA	4
C-1	20	PAHZZ	5945-00-927-7659	MS27222-1	96906	RELAY, EM	EA	2
C-1	21	XDHZZ	5940-00-143-4780	MS25036-108	96906	TERMINAL, LUG	EA	4
C-1	22	XDHZZ		5066287-2	57958	LABEL, INSTRUCTION	EA	1
C-1	23	XDHZZ		5066229-1	57958	SHIELD, HV	EA	1
C-1	24	XDHHH		5065665-3	57958	COVER ASSY, ACCESS	EA	1
C-1	25	XDHZZ	5320-00-117-6938	MS20426AD3-4	96906	RIVET, SOLID	EA	20
C-1	26	XDHZZ		DPYS7900P-4-B-2	08524	SCREW ASSY, PNL	EA	40
C-1	27	XDHZZ	5305-01-106-7503	NAS1189E3P7B	80205	SCREW, MACHINE	EA	12
C-1	28	XDHZZ		5066287-1	57958	LABEL, INSTRUCTION	EA	1
C-1	29	XDHZZ	5940-00-143-4794	MS25036-112	96906	TERMINAL, LUG	EA	25
C-1	30	XDHZZ		1951-1-2433-1	15942	STANDOFF, SHIELD	EA	6
C-1	31	XDHZZ	5310-00-619-1148	MS15795-808	96906	WASHER, FLAT	EA	31
C-1	32	XDHZZ	5310-00-933-8120	MS35338-138	96906	WASHER, LOCK	EA	30
C-1	33	XDHZZ	5305-00-059-3659	MS51958-63	96906	SCREW, MACHINE	EA	24
C-1	34	PAHZZ	5945-00-997-9361	MS27222-3	96906	RELAY, EM	EA	1
C-1	34A	XDHZZ	5325-00-074-3301	MS21266-2N	96906	GROMMET, PLASTIC	EA	1
C-1	35	XDHZZ	5305-00-056-9961	MS24693-C4	96906	SCREW, MACHINE	EA	20
C-1	36	PAHZZ	5935-00-826-0850	MS3112E22-21S	96906	CONN, RCPT, ELEC	EA	1
C-1	37	XDHZZ	5305-00-054-5649	MS51957-15	96906	SCREW, MACHINE	EA	16

(1) ILLUSTRATION		(2)	(3)	(4)	(5)	(6)	(7)	(8)
(a) FIG NO.	(b) ITEM NO.	SMR CODE	NATIONAL STOCK NUMBER	PART NUMBER	FSCM	DESCRIPTION USABLE ON CODE	U/M	QTY INC IN UNIT
C-1	38	PAHZZ	5935-00-880-4628	MS3112E24-61S	96906	CONN, RCPT, ELEC	EA	1
C-1	39	XDHZZ	5305-00-958-2918	MS24693-C26	96906	SCREW, MACHINE	EA	10
C-1	39A	XDHZZ		5065665-502	57958	RETAINER, GSKT	EA	1
C-1	39B	XDHZZ		20-15108	53217	SHIELDING, GSKT, ELEC	EA	1
C-1	40	PAHZZ	5935-00-752-2773	MS3102R24-10OP	96906	CONN, RCPT, ELEC	EA	1
C-1	41	XDHZZ	5310-00-934-9765	MS35650-304	96906	NUT, PLAIN, HEX	EA	3
C-1	42	XDHZZ	5310-00-209-1239	MS35335-60	96906	WASHER, LOCK	EA	3
C-1	43	XDHZZ	5305-00-889-2991	MS24693-C48	96906	SCREW, MACHINE	EA	4
C-1	44	XDHZZ	5310-01-067-9589	MS35338-137	96906	WASHER, LOCK	EA	78
C-1	45	XDHZZ	5310-00-880-5978	MS15795-807	96906	WASHER, FLAT	EA	32
C-1	45A	XDHZZ		01-0401-0541	28817	SHIELDING, GSKT, ELEC	EA	AR
C-1	46	PAHZZ	5935-00-835-4337	MS3102R32-1P	96906	CONN, RCPT, ELEC	EA	1
C-1	47	XDHZZ	5310-00-837-1381	NAS671C8	80205	NUT, PLAIN, HEX	EA	4
C-1	48	PAHZZ	5935-00-062-5083	MS3112E 18- 1S	96906	CONN, RCPT, ELEC	EA	1
C-1	49	XDHZZ		5066287-3	57958	LABEL, INSTRUCTION	EA	2
C-1	50	XDHHH		5065665-4	57958	COVER ASSY, ACCESS	EA	1
C-1	51	XDHHH	5915-01-207-3458	C5074616-1	57958	FILTER ASSY, RFI	EA	1
C-1	52	XDHZZ		5065667-1	57958	BRACKET ASSY	EA	1
C-1	53	PAHZZ	5930-00-843-8990	MS24658-22D	96906	SWITCH, TOGGLE	EA	1
C-1	54	XDHZZ	5305-00-054-6670	MS51957-45	96906	SCREW, MACHINE	EA	4
C-1	55	PAHZZ	6210-00-176-4928	LH89/1	81349	LAMPHOLDER	EA	1
C-1	56	PAOZZ	6240-00-763-7744	MS25237-387	96906	LAMP, INCAND	EA	1
C-1	57	PAOZZ	6210-00-115-2591	LC37YD2	81349	LENS, LIGHT	EA	1
C-1	58	XDHZZ	5940-00-143-4775	MS25036-156	96906	TERMINAL, LUG	EA	12
C-1	59	XDHZZ		FBA5	08730	HANDLE, BOW	EA	2
C-1	60	XDHHH		C5074581-1	57958	PANEL ASSY, FRONT	EA	1
C-1	61	XDHZZ		C5074128-7	57958	PLATE, IDENT	EA	1
C-1	62	XDHZZ	5310-00-402-4589	6314D-SS-1032-7	06540	INSERT, SCR THD	EA	4
C-1	63	XDHZZ	5305-00-930-4377	6140-SS-1032-7	06540	SCREW, EXT RLV	EA	4
C-1	63A	XDHZZ		FHA440-8	46384	STUD, SLFLKG	EA	14
C-1	64	XDHZZ	5940-00-010-2898	MS25036-149	96906	TERMINAL, LUG	EA	12
C-1	65	XDHZZ	5940-00-143-4777	MS25036-157	96906	TERMINAL, LUG	EA	6
C-1	66	XDHZZ	5940-00-230-0515	MS25036-154	96906	TERMINAL, LUG	EA	4
C-1	67	PAHZZ	5925-00-914-3505	MS22073-2	96906	CIRCUIT BREAKER	EA	5
C-1	68	PAHZZ	5925-00-686-3297	MS25244-5	96906	CIRCUIT BREAKER	EA	8
C-1	69	PAHZZ	5925-00-681-4952	MS25244-10	96906	CIRCUIT BREAKER	EA	1
C-1	70	PAHZZ	5925-00-912-8343	MS22073-1	96906	CIRCUIT BREAKER	EA	2
C-1	71	PAHZZ	5925-00-686-3301	MS25244-15	96906	CIRCUIT BREAKER	EA	3
C-1	72	PAHZZ		MS90351-25	96906	CIRCUIT BREAKER	EA	1

(1)		(2)	(3)	(4)	(5)	(6)	(7)	(8)
ILLUSTRATION		SMR CODE	NATIONAL STOCK NUMBER	PART NUMBER	FSCM	DESCRIPTION	U/M	QTY INC IN UNIT
(a) FIG NO.	(b) ITEM NO.							
C-1	73	PAHZZ	5306-00-584-8408	MS90351-5	96906	CIRCUIT BREAKER	EA	1
C-1	74	XDHHH		5065638-1	57958	CHASSIS ASSY	EA	1
C-1	75	XDHZZ		1951-1-2411-1	15942	BAR, BUS	EA	1
C-1	76	XDHZZ	5940-00-204-8990	MS25036-111	96906	TERMINAL, LUG	EA	13
C-1	77	XDHZZ	5940-00-204-8966	MS25036-102	96906	TERMINAL, LUG	EA	77
C-1	78	XDHZZ	5305-00-054-6650	MS51957-26	96906	SCREW, MACHINE	EA	17
C-1	79	XDHZZ		5065639-1	57958	COVER, PLATE	EA	1
C-1	80	PAHZZ	5935-00-893-7952	MS3112E14-5S	96906	CONN, RCPT, ELEC	EA	17
C-1	81	XDHZZ	5305-00-225-6400	MS24693-C3	96906	SCREW, MACHINE	EA	8
C-1	82	XA	5310-00-589-7962	FE-440	46384	NUT, SLFLKG, CL	EA	2
C-1	83	XDHZZ	5305-00-066-7328	MS24693-C27	96906	SCREW, MACHINE	EA	42
C-1	84	XDHZZ		5065640-1	57958	PLATE ASSY, REAR	EA	1
C-1	85	PAHZZ	5935-00-826-1020	MS3112E12-10S	96906	CONN, RCPT, ELEC	EA	1
C-1	86	PAHZZ	5935-01-121-2157	SM3102R24-67S	77820	CONN, RCPT, ELEC	EA	1
C-1	87	XDHZZ		1951-1-2413-1	15942	BAR, BUS	EA	1
C-1	88	XDHZZ	5940-14-013-8288	MS25036-107	96906	TERMINAL, LUG	EA	3
C-1	89	XDHZZ		1951-1-2412-1	15942	BAR, BUS	EA	1
C-1	90	XDHZZ	5340-00-827-4024	MS21209C0420	96906	INSERT, SCR THD	EA	42
C-1	91	XDHZZ	5305-00-068-6605	MS24693-C6	96906	SCREW, MACHINE	EA	6
C-1	92	PAHZZ	5915-01-221-8135	CF674-2	96733	FILTER, RFI	EA	1
C-1	93	PAHZZ		LMF-2623	28815	FILTER, PWR LINE	EA	5
C-1	94	XDHZZ		5065641-1	57958	PLATE, FRONT	EA	1
C-1	95	XDHZZ	5310-00-934-9759	MS35649-284	96906	NUT, HEX, PL	EA	20
C-1	96	XDHZZ	5940-00-113-8184	MS25036-150	96906	TERMINAL, LUG	EA	4
C-1	97	XDHZZ	5305-00-088-9665	MS24693-C29	96906	SCREW, MACHINE	EA	8
C-1	98	XDHZZ	6150-00-519-2714	601J	75382	LINK, CONNECTING	EA	25
C-1	99	XDHZZ	5940-00-283-5280	MS25036-106	96906	TERMINAL, LUG	EA	20
C-1	100	XDHZZ	5940-01-013-8287	MS25036-153	96906	TERMINAL, LUG	EA	42
C-1	101	XDHZZ	5307-00-075-2730	FHS-032-8	46384	STUD, SLFLKG	EA	2
C-1	102	XDHZZ	5310-01-144-2710	FE-632	46384	NUT, SLFLKG, CL	EA	2
C-1	103	XDHZZ	5610-00-725-8534	CLSS-032-2	46384	NUT, PL, CL	EA	6
C-1	104	XDHZZ	5310-01-110-2458	NAS620C4L	80205	WASHER, FLAT	EA	8
C-1	105	XDHZZ	5305-00-054-6667	MS51957-42	96906	SCREW, MACHINE	EA	50

SECTION III. SPECIAL TOOLS LIST

(Not Applicable)

SECTION IV. NATIONAL STOCK NUMBER AND PART NUMBER INDEX

NATL STOCK NUMBER	FIGURE	ITEM	NATL STOCK NUMBER	FIGURE	ITEM
	C-1	1	5310-00-402-4589	C-1	62
	C-1	3	5310-00-589-7962	C-1	82
	C-1	15	5310-00-595-6211	C-1	6
	C-1	17	5310-00-619-1148	C-1	31
	C-1	22	5310-00-722-5998	C-1	14
	C-1	23	5310-00-837-1381	C-1	47
	C-1	24	5310-00-880-5978	C-1	45
	C-1	26	5310-00-881-9981	C-1	8
	C-1	28	5310-00-929-6395	C-1	13
	C-1	30	5310-00-933-8118	C-1	7
	C-1	39A	5310-00-933-8120	C-1	32
	C-1	39B	5310-00-934-9759	C-1	95
	C-1	45A	5310-00-934-9765	C-1	41
	C-1	49	5310-01-067-9589	C-1	44
	C-1	50	5310-01-110-2458	C-1	104
	C-1	52	5310-01-144-2710	C-1	102
	C-1	59	5320-00-117-6010	C-1	9
	C-1	60	5320-00-117-6938	C-1	25
	C-1	61	5325-00-074-3301	C-1	34A
	C-1	63A	5340-00-827-4024	C-1	90
	C-1	72	5610-00-725-8534	C-1	103
	C-1	74	5915-01-207-3458	C-1	51
	C-1	75	5915-01-221-8135	C-1	92
	C-1	79	5925-00-681-4952	C-1	69
	C-1	84	5925-00-686-3297	C-1	68
	C-1	87	5925-00-686-3301	C-1	71
	C-1	89	5925-00-912-8343	C-1	70
	C-1	93	5925-00-914-3505	C-1	67
	C-1	94	5930-00-843-8990	C-1	53
5305-00-054-5649	C-1	37	5935-00-062-5083	C-1	48
5305-00-054-6650	C-1	78	5935-00-752-2773	C-1	40
5305-00-054-6656	C-1	19	5935-00-826-0850	C-1	36
5305-00-054-6667	C-1	105	5935-00-826-1020	C-1	85
5305-00-054-6670	C-1	54	5935-00-827-1545	C-1	10
5305-00-056-9961	C-1	35	5935-00-835-4337	C-1	46
5305-00-059-3659	C-1	33	5935-00-836-0082	C-1	11
5305-00-066-7328	C-1	83	5935-00-846-2176	C-1	4
5305-00-068-6605	C-1	91	5935-00-880-4628	C-1	38
5305-00-088-9665	C-1	97	5935-00-893-7952	C-1	80
5305-00-225-6400	C-1	81	5935-01-080-5000	C-1	16
5305-00-889-2991	C-1	43	5935-01-121-2157	C-1	86
5305-00-930-4377	C-1	63	5940-00-010-2898	C-1	64
5305-00-958-2918	C-1	39	5940-00-113-8184	C-1	96
5305-01-106-7503	C-1	27	5940-00-143-4775	C-1	58
5306-00-584-8408	C-1	73	5940-00-143-4777	C-1	65
5307-00-075-2730	C-1	101	5940-00-143-4780	C-1	21
5310-00-208-3786	C-1	5	5940-00-143-4794	C-1	29
5310-00-208-3786	C-1	12	5940-00-204-8966	C-1	77
5310-00-209-1239	C-1	42	5940-00-204-8990	C-1	76

NATIONAL STOCK NUMBER AND PART NUMBER INDEX

NATL STOCK NUMBER	FIGURE	ITEM	NATL STOCK NUMBER	FIGURE	ITEM
5940-00-230-0515	C-1	66			
5940-00-283-5280	C-1	99			
5940-00-983-6087	C-1	2			
5940-01-013-8287	C-1	100			
5940-14-013-8288	C-1	88			
5945-00-927-7659	C-1	20			
5945-00-997-9361	C-1	34			
5945-01-044-4645	C-1	18			
6150-00-519-2714	C-1	98			
6210-00-115-2591	C-1	57			
6210-00-176-4928	C-1	55			
6240-00-763-7744	C-1	56			

PART NUMBER TO FIGURE AND ITEM NUMBER INDEX

PART NUMBER	FSCM	FIGURE	ITEM	PART NUMBER	FSCM	FIGURE	ITEM
CF674-2	96733	C-1	92	MS27222-3	96906	C-1	34
CLSS-032-2	46384	C-1	103	MS27401-16	96906	C-1	18
C5074128-7	57958	C-1	61	MS3102R24-10P	96906	C-1	40
C5074580-1	57958	C-1	1	MS3102R32-1P	96906	C-1	46
C5074581-1	57958	C-1	60	MS311Z12-10S	96906	C-1	85
C5074616-1	57958	C-1	51	MS112E14-5S	96906	C-1	80
DPYS7900P-4-B-208524		C-1	26	MS3112E16-26S	96906	C-1	10
FBA5	08730	C-1	59	MS311E16-8S	96906	C-1	11
FE-440	46384	C-1	82	MS112E18-11S	96906	C-1	48
FE-632	46384	C-1	102	MS3112E20-16S	96906	C-1	4
FHA440-8	46384	C-1	63A	MS3112E22-21S	96906	C-1	36
FHS-032-8	46384	C-1	101	MS3112E24-61S	96906	C-1	38
LC37YD2	81349	C-1	57	MS35335-60	96906	C-1	42
LH89/1	81349	C-1	55	MS35338-135	96906	C-1	7
LMF-2623	28815	C-1	93	MS35338-136	96906	C-1	13
MS15795-803	96906	C-1	6	MS35338-137	96906	C-1	44
MS15795-805	96906	C-1	14	MS35338-138	96906	C-1	32
MS15795-807	96906	C-1	45	MS35649-284	96906	C-1	95
MS15795-808	96906	C-1	31	MS35650-304	96906	C-1	41
MS20426AD2-3	96906	C-1	9	MS51957-15	96906	C-1	37
MS20426AD3-4	96906	C-1	25	MS51957-26	96906	C-1	78
MS21209C0420	96906	C-1	90	MS51957-32	96906	C-1	19
MS21266-2N	96906	C-1	34A	MS51957-42	96906	C-1	105
MS22073-1	96906	C-1	70	MS51957-45	96906	C-1	54
MS22073-2	96906	C-1	67	MS51958-63	96906	C-1	33
MS24658-22D	96906	C-1	53	MS601-10-GEE-1A	75382	C-1	15
MS24693-C26	96906	C-1	39	MS90351-25	96906	C-1	72
MS24693-C27	96906	C-1	83	MS90351-5	96906	C-1	73
MS24693-C29	96906	C-1	97	NAS1068CO4M	80205	C-1	8
MS24693-C3	96906	C-1	81	NAS1189E3P7B	80205	C-1	27
MS24693-C4	96906	C-1	35	NAS620C4L	80205	C-1	104
MS24693-C48	96906	C-1	43	NAS671C4	80205	C-1	5
MS24693-C6	96906	C-1	91	NAS671C6	80205	C-1	12
MS25036-102	96906	C-1	77	NAS671C8	80205	C-1	47
MS25036-106	96906	C-1	99	SM3102R24-67S	77820	C-1	86
MS25036-107	96906	C-1	88	S0-1049-8772	35344	C-1	16
MS25036-108	96906	C-1	21	01-0401-0541	28817	C-1	45A
MS25036-111	96906	C-1	76	12-133295-1	28815	C-1	3
MS25036-112	96906	C-1	29	1951-1-2411-1	15942	C-1	75
MS25036-149	96906	C-1	64	1951-1-2412-1	15942	C-1	89
MS25036-150	96906	C-1	96	1951-1-2413-1	15942	C-1	87
MS25036-153	96906	C-1	100	1951-1-2433-1	15942	C-1	30
MS25036-154	96906	C-1	66	20-15108	53217	C-1	39B
MS25036-156	96906	C-1	58	38TB10	81349	C-1	2
MS25036-157	96906	C-1	65	5065638-1	57958	C-1	74
MS25237-387	96906	C-1	56	5065639-1	57958	C-1	78
MS25244-10	96906	C-1	69	5065640-501	57958	C-1	84
MS25244-15	96906	C-1	71	5065641-1	57958	C-1	94
MS25244-5	96906	C-1	68	5065665-3	57958	C-1	24
MS27222-1	96906	C-1	20	5065665-4	57958	C-1	50

PART NUMBER TO FIGURE AND ITEM NUMBER INDEX

PART NUMBER	FSCM	FIGURE	ITEM	PART NUMBER	FSCM	FIGURE	ITEM
5065665-502	57958	C-1	39A				
5065667-1	57958	C-1	52				
5065668-1	57958	C-1	17				
5066229-1	57958	C-1	23				
5066287-1	57958	C-1	28				
5066287-2	57958	C-1	22				
5066287-3	57958	C-1	49				
601J	75382	C-1	98				
6140-SS-1032-7	06540	C-1	63				
6314D-SS-1032-7	06540	C-1	62				

APPENDIX D
EXPENDABLE SUPPLIES AND MATERIALS LIST

SECTION I. INTRODUCTION

D-1. SCOPE

This appendix lists expendable supplies and materials you will need to operate and maintain the power distribution box. These items are authorized to you by CTA 50-970, Expendable Items (Except Medical, Class V, Repair Parts, and Heraldic Items).

D-2. EXPLANATION OF COLUMNS

a. Column(1)- Item number. This number is assigned to the entry in the listing and is referenced in the narrative instructions to identify the material (e.g., "Use cleaning compound, item 5, App. D").

b. Column(2)- Level. This column identifies the lowest level of maintenance that requires the listed item.

(enter as applicable)

C-Operator/Crew

O-Organizational Maintenance

F-Direct Support Maintenance

H-General Support Maintenance

c. Column(3)-National Stock Number. This is the National stock number assigned to the item; use it to request or requisition the item.

d. Column(4)-Description. Indicates the Federal item name and, if required, a description to identify the item. The last line for each item indicates the Federal Supply Code for Manufacturer (FSCM) in parentheses followed by the part number.

e. Column(5)-Unit of Measure (U/M). Indicates the measure used in performing the actual maintenance function. This measure is expressed by a two-character alphabetical abbreviation (e.g., ea, in, pr). If the unit of measure differs from the unit of issue, requisition the lowest unit of issue that will satisfy your requirements.

SECTION II. EXPENDABLE SUPPLIES AND MATERIALS LIST

(1)	(2)	(3)	(4)	(5)
<u>ITEM NO.</u>	<u>LEVEL</u>	<u>NSN</u>	<u>DESCRIPTION</u>	<u>U/M</u>
1	H	8040-00-092-2816	Adhesive, clear, type 608	oz
2	H	8029-00-246-8806	Brush, soft	ea
3	H		Compound, silicone, type MA-509A	TBD
4	H	8305-00-267-3015	Cloth, lint-free	ro
5			Gasket, electrical shield	ft
6	H	8415-00-200-7013	Gloves, rubber, heavy duty	pr
7	H	*	Sleeving, insulated, heatshrink, 0.125 ID black	in
8	H	*	Sleeving, insulated, heatshrink, 0.187 ID black	in
9	H	*	Sleeving, insulated, heatshrink, 0.250 ID, black	in
10	H	*	Sleeving, insulated, heatshrink, 0.375 ID black	in
11	H	*	Sleeving, insulated, heatshrink, 0.500, black	in
12	H	3439-01-011-7281	Solder, SN60WRAP3	ro
13	H	6850-00-984-5853	Trichlorotrifluoroethane	gl
14	H		Wire, electrical, 12 AWG, black	ft
15	H		Wire, electrical, 12 AWG, gray	ft
16	H		Wire, electrical, 12 AWG, red	ft
17	H		Wire, electrical, 12 AWG, white	ft
18	H		Wire, electrical, 16 AWG, black	ft
19	H		Wire, electrical, 16 AWG, gray	ft
20	H		Wire, electrical, 16 AWG, red	ft
21	H		Wire, electrical, 16 AWG, white	ft
22	H		Wire, electrical, 20 AWG, black	ft
23	H		Wire, electrical, 20 AWG, gray	ft
24	H		Wire, electrical, 20 AWG, red	ft
25	H		Wire, electrical, 20 AWG, white	ft

* Obtain applicable size length from Kit, Heatshrink Tubing, P/N FIT221MSI, NSN 5970-01-026-1877.

APPENDIX E

ILLUSTRATED LIST OF MANUFACTURED ITEMS

E-1. Introduction.

This appendix includes complete instruction for making items authorized to be manufactured or fabricated at organizational unit maintenance.

A part number index in alphanumeric order is provided for cross-referencing the part number of the item to be manufactured to the figure which covers fabrication criteria.

All bulk materials needed for manufacture of an item are listed by part number or specification number in a tabular list on the illustration.

E-2. Manufactured Items Part Number Index.

<u>Nomenclature</u>	<u>Figure No.</u>
Test Cable W1	E-1
Test Cable W2	E-2
Connector P8	E-3
Connector P2	E-4

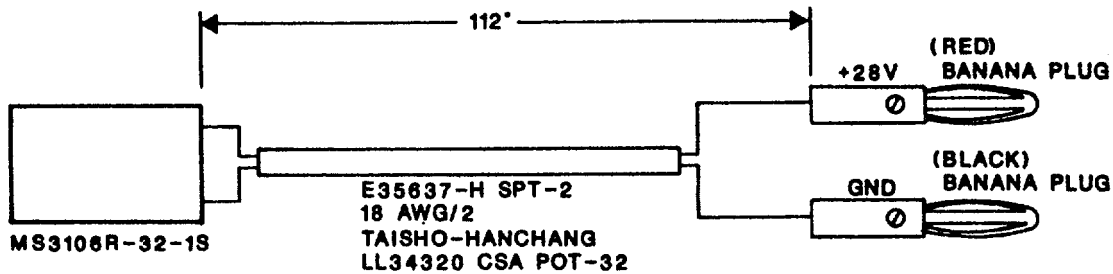

Parts List

1. Connector, MS3106-32-1S
2. Wire E35637-H SPT-2 18 AWG/2 TAISHO-HANCHANG LL34320 CSA POT-32
3. Banana Plug, Red
4. Banana Plug, Black

Wire List

<u>From</u>	<u>To</u>	<u>Purpose</u>
+28 Vdc	E	+28 V
+28 Vdc	B	Return

Figure E1. Test Cable W1

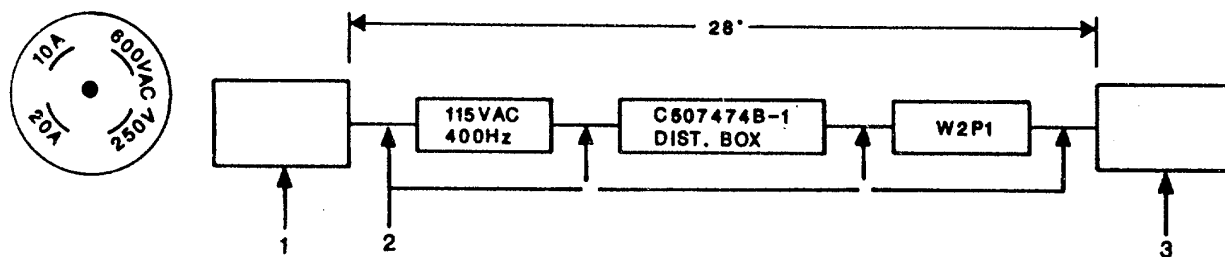

Parts List

1. Connector, 115Vac 3-Phase with Neutral, 400 Hz, Hubbell Twist-Lock or equivalent
2. Wire 18 AWG/3 TAISHO-HANCHANG, LL34320 CSA POT-32 or equivalent, length as required
3. Connector, MS3106R24-10S

Wire List

<u>From</u>		<u>To</u>
115 Vac Q1	C	Connector P1
115 Vac Q2	D	Connector P1
115 Vac Q3	E	Connector P1
Neutral	F	Connector P1
Ground	G	Connector P1

Figure E-2. Test Cable W2

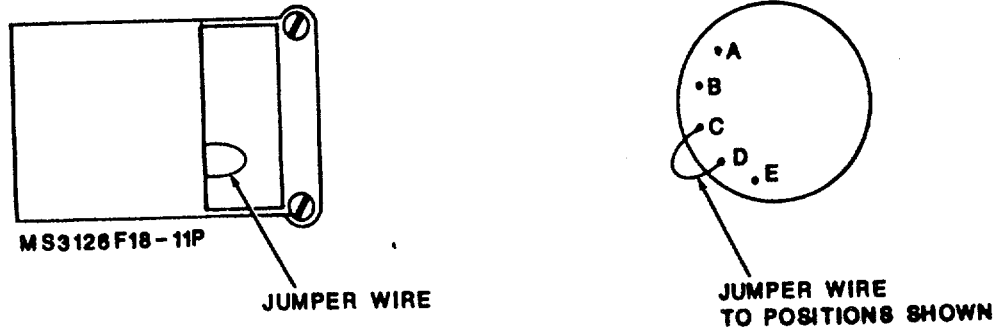

Parts List

- 1. Connector, MS3126F18-11P
- 3. Jumper wire

Figure E-3. Connector Assy P8

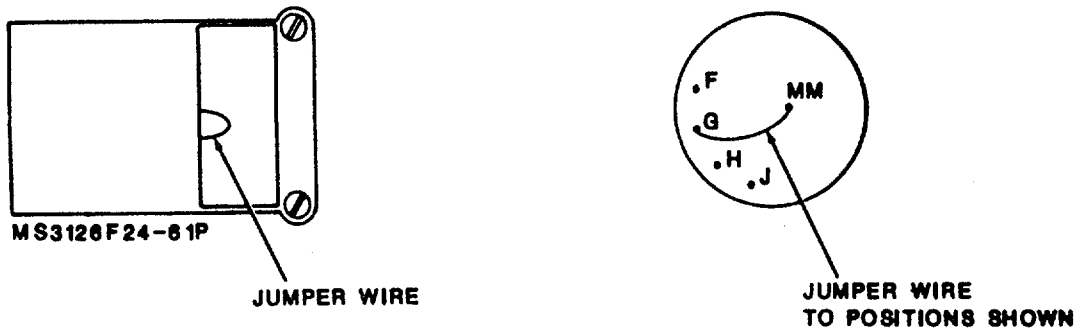

Parts List

- 1. Connector, MS3126F24-61P
- 2. Jumper Wire

Figure E-4. Connector Assy P2

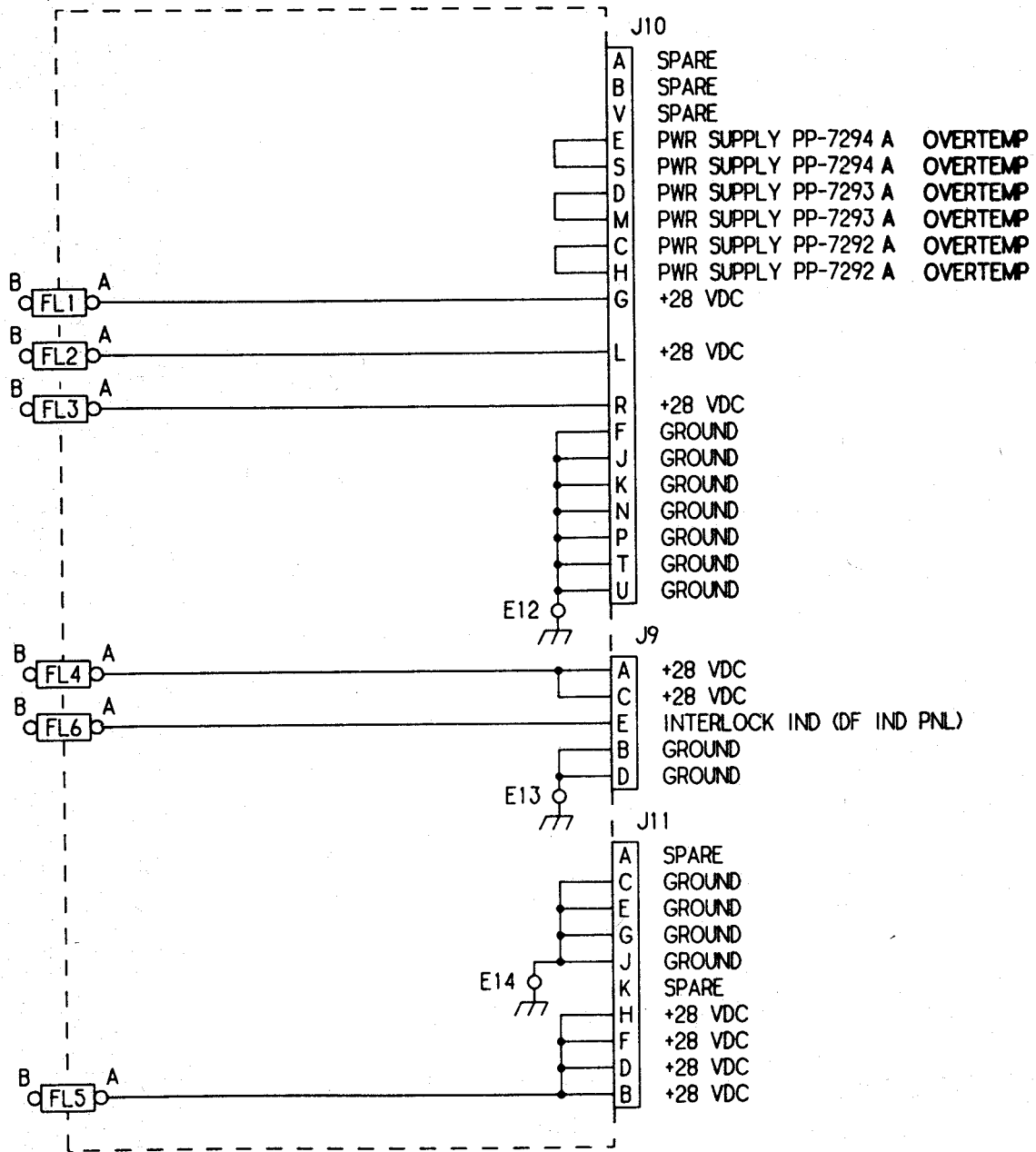

NOTES (UNLESS OTHERWISE SPECIFIED):

1. PARTIAL REFERENCE DESIGNATIONS ARE SHOWN. FOR COMPLETE REFERENCE DESIGNATIONS, PREFIX WITH APPLICABLE UNIT AND ASSEMBLY DESIGNATIONS.

FO-2. RFI Filter Assembly Schematic Diagram

GLOSSARY

Abbreviated terms used in this manual and their spelled-out equivalents are listed below.

<u>Term</u>	<u>Equivalent</u>
EIR	Equipment Improvement Recommendations
LRUs	Line replaceable units
Power distribution box	Distribution Box J-3986/ALQ-151(V)
RFI	RF interference
TAMMS	The Army Maintenance Management System

INDEX

	Paragraph figure/table	Page
A		
AC Connectors Neutral and Ground Checks.....	5-3c	5-2
AC Control Circuit	3-3a(2)	3-3
AC Input Test Setup	F5-2	5-13
AC Output Connectors Continuity Checks	T5-5	5-14
AC Output Neutral and Ground Pins.....	T5-2	5-3
AC Power Distribution		
Simplified Schematic Diagram	F3-3	3-6
Circuit	3-3c	3-3
Circuit Breakers	T3-2	3-7
AC Power Resistance Checks	5-3a	5-1
Access Cover Repair.....	5-12x	5-36
Administrative Storage.....	1-4	1-1
Army Regulations.....	A-6	A-2
Assembly, RFI Filter		
Description	3-3d	3-7
Removal	5-10c	5-20
Replacement	5-11a	5-21
B		
Bus Bar E12, E13, and E14 Removal and Replacement	5-12h	5-27
C		
Cable Mounts and Grommet Repair	5-12h	5-34
Checks		
AC Connectors Neutral and Ground	5-3c	5-2
AC Output Connectors Continuity.....	T5-5	5-14
AC Power Resistance.....	5-3a	5-1
DC Connectors Ground.....	5-3d	5-2
DC Voltage Output	T5-6	5-15
DC Power Resistance	5-3b	5-2
Circuit Breakers		
AC Power Distribution	T3-2	3-7
CB1 Distribution	3-3c(l)	3-7
CB2 Distribution	3-3c(2)	3-7
CB12 Distribution	3-3b(1)	3-3
CB20 Distribution	3-3b(2)	3-3
DC Power Distribution	T3-1	3-5
Removal and Replacement	5-12b, F5-6	5-22, 5-23
Circuits		
AC Power Distribution	3-3c	3-3
Control	3-3a, F3-1	3-1, 3-2
DC Power Distribution	3-3b F3-2	3-3 3-4

INDEX -- Continued

Subject	Paragraph figure/table	Page
Cleaning of Power Distribution Box	5-9b	5-19
Common Table of Allowances.....	A-4	A-2
Component Shelf Removal and Replacement.....	5-12n	5-30
Connector J1 through J8 Removal and Replacement.....	5-12o	5-31
Connector J9, J10, and J11 Removal and Replacement	5-12i	5-27
Connector P2	FE-4	E-4
Connector P8	FE-3	E-4
Connecting Link Removal and Replacement	5-12m	5-30
.....	F5-5	5-18
Connector J1 Resistance Measurements.....	T5-1	5-2
Continuity Checks, AC Output Connectors	T5-5	5-14
Control Circuits		
Description	3-3a	3-1
Simplified Schematic Diagram.....	F3-1	3-2
Cover, Top and Bottom		
Removal	5-10a	5-20
Replacement of	5-11c	5-22

D

DC Connectors Ground Checks.....	5-3d	5-2
DC Control Circuit	3-3a(l)	3-1
DC Input Test Setup.....	F5-1	5-12
DC Output Connector Ground Measurements	T5-3	5-3
DC Power Distribution		
Circuit	3-3b	3-3
Circuit Breakers	T3-1	3-5
Simplified Schematic Diagram.....	F3-2	3-4
DC Power Resistance Checks	5-3b	5-2
DC Voltage Output Checks	T5-6	5-15
Destruction of Army Materiel to Prevent Enemy Use	1-3	1-1
Direct Support Maintenance Instructions, Scope	4-1	4-1
Distribution Box J-3986/ALQ-151(V).....	F1-1	1-2
	FC-1	C-10

E

Errors, Reporting of.....	1-5	1-1
Externally Relieved (Captive) Screw Removal and Replacement	5-12v	5-35

INDEX -- Continued

Subject	Paragraph figure/table	Page
F		
Federal Supply Code for Manufacturer (FSCM).....	C-3e	C-8
Filter FI through F5 Removal and Replacement	5-12f, F5-4	5-25, 5-17
Filter FL6 Removal and Replacement	5-12g	5-26
Front Panel Removal and Replacement.....	5-12r	5-32
Functioning of Equipment, Scope	3-1	3-1
G		
General Support Maintenance Instructions, Scope	5-1	5-1
General Support Test Procedure,	5-13	5-39
General		
H		
Handle Replacement.....	5-12q	5-32
High-Voltage Shield		
Removal	5-10b	5-20
Replacement	5-11b	5-22
Identification Plate Removal and Replacement	5-12u	5-34
Illustrated List of Manufactured Items	E-1	E-1
Inspection of Power Distribution Box	5-9a	5-15
Insulating Strip Removal and Replacement.....	5-121	5-29
Interlock Jumpers.....	3-3a(3)	3-3
J		
Jumpers, Interlock.....	3-3a(3)	3-3
L		
Lampholder XDSI Removal and Replacement	5-12p	5-32
M		
Maintenance		
Code.....	C-3b(2)	C-5
Direct Support Instructions.....	4-1	4-1
Forms and Records ;	1-2	1-1
Functions	B-2	B-1
General Support Instructions, Scope.....	5-1	5-1

INDEX -- Continued

Subject	Paragraph figure/table	Page
Organizational Instructions, Scope	2-1	2-1
Procedures	5-9	5-15
Maintenance Allocation Chart for Power Distribution Box	TB-1	B-5
Manufactured Items Part Number Index	E-2	F-1
Measurements and Data	5-3	5-1
Measurements, Connector J1 Resistance	T5-1	5-2
MISSION POWER Switch S1 Removal and Replacement	5-12a	5-22
N		
National Stock Number and Part Number Index	C-2c	C-3
O		
Organizational Maintenance Instructions, Scope	2-1	2-1
Power Distribution Box		
Component Locations	F5-3	5-16
Equipment Descriptions	1-7	1-3
Front View	F1-1	1-2
Functional Description	3-3	3-1
Maintenance Allocation Chart	TB-1	B-5
Power and Signal Connections	T-1	1-4
Repair Parts List	C-2a, FC-1	C-3, C-10
Schematic Diagram	FO-1	
Tabulated Data	1-8	1-3
Troubleshooting Procedure	5-7, T5-4	5-5, 5-6
R		
Recoverability Code	C-3b(3)	C-7
References		
Army Regulations	A-6	A-2
Common Table of Allowances	A-4	A-2
Forms	A-7	A-3
Pamphlets	A-5	A-2
Supply Bulletins	A-3	A-2
Technical Manuals	A-2	A-1
Relay K1, K2, or K3 Removal and Replacement	5-12e	5-25
Relay K4 Removal and Replacement	5-12c	5-24
Removal of		
Cover, Top and Bottom	5-10a	5-20
High-Voltage Shield	5-10b	5-20

INDEX -- Continued

Subject	Paragraph figure/table	Page
RFI Filter Assembly A1	5-10c	5-20
Removal and Replacement of		
Bus Bar E12, E13, and E14	5-12h	5-27
Circuit Breakers	5-12b	5-22
Component Shelf	5-12n	5-30
Connector J1 through J8	5-12o	5-31
Connector J9, J10, and J11	5-12i	5-27
Connecting Link	5-12m	5-30
Externally Relieved (Captive) Screws	5-12v	5-35
Filter FL1 through FL5.	5-12f	5-25
Filter FL6	5-12g	5-27
Front Panel	5-12r	5-32
Handle	5-12q	5-32
Identification Plate	5-12u	5-34
Insulating Strip	5-12l	5-29
Lampholder XDSI	5-12p	5-32
MISSION POWER SWITCH S1	5-12a	5-22
Relay K4	5-12c	5-24
Relays K1, K2, or K3.	5-12e	5-25
Riveting	5-12s	5-33
Shield Gasket	5-12w	5-35
Socket XK4	5-12d	5-24
Terminal Board TB2 and TB3	5-12j	5-28
Terminal Board TB1	5-12k	5-29
Repair of Cable Mounts and Grommets	5-12t	5-34
Repair Parts, How to Locate	C-5	C-8
Repair Parts List	C-2a, FC-1	C-3, C-10
Repair Procedures	5-12	5-22
Replacement Procedures	5-11	5-20
Replacement of		
Cover, Top and Bottom	5-11c	5-22
High-Voltage Shield	5-11b	5-22
RFI Filter Assembly AI	5-11a	5-21
Replacement Procedures.	5-11	5-20
Reporting Equipment Improvement		
Recommendations (EIR)	1-6	1-1
Reporting of Errors	1-5	1-1
RFI Filter Assembly AI		
Description	3-3d	3-7
Schematic Diagram	FO-2	
Removal	5-10c	5-20
Replacement	5-11a	5-21
Repair	5-12y	5-37
Riveting Removal and Replacement	5-12s	5-33

INDEX -- Continued

Subject	Paragraph figure/table	Page
S		
Shield Gasket Removal and Replacement	5-12w	5-35
Shield, High-Voltage		
Removal	5-10b	5-20
Replacement	5-11b	5-22
Socket XK4 Replacement	5-12d	5-24
Source, Maintenance, and Recoverability		
(SMR) Codes	C-3b	C-3
Special Tools List	C-2b	C-3
Storage, Administrative.....	1-4	1-1
Supply Bulletins	A-3	A-2
T		
Tabulated Data	1-8	1-3
Terminal Board TB2 or TB3 Removal and Replacement	5-12j	5-28
Terminal Board TB1 Removal and Replacement.....	5-12k	5-28
Technical Manuals	A-2	A-1
Test	5-14	5-39
Test Cable W1 Manufacture.....	E-2, FE1	E-1,
.....	FE1	E-2
Test Cable W2 Manufacture.....	E-2,	E-1,
.....	FE2	E-3
Test Equipment.....	5-5b	5-4
Test Setup		
AC Input.....	F5-2	5-13
DC Input.....	F5-1	5-12
Threaded Insert Removal and Replacement Tools	F5-7	5-38
Tool and Test Equipment Requirements for Power		
Distribution Box.....	TB-2	B-6
Tools and Equipment Required	5-4,	5-4,
.....	5-5	5-4
Top and Bottom Cover		
Removal	5-10a	5-20
Replacement.....	5-11c	5-22
Troubleshooting Procedure	5-7,	5-5,
.....	T5-4	5-6

U, V, W, X, Y, Z

By Order of the Secretary of the Army:

CARL E. VUONO
General, United States Army
Chief of Staff

Official:

WILLIAM J. MEEHAN II
Brigadier General, United States Army
The Adjutant General

Distribution:

☆U.S. GOVERNMENT PRINTING OFFICE : 1988 0 - 220-823

RECOMMENDED CHANGES TO EQUIPMENT TECHNICAL PUBLICATIONS



THEN...JOT DOWN THE DOPE ABOUT IT ON THIS FORM. CAREFULLY TEAR IT OUT, FOLD IT AND DROP IT IN THE MAIL.

SOMETHING WRONG WITH PUBLICATION

FROM: (PRINT YOUR UNIT'S COMPLETE ADDRESS)

DATE SENT

PUBLICATION NUMBER

PUBLICATION DATE

PUBLICATION TITLE

BE EXACT PIN-POINT WHERE IT IS

PAGE NO.	PARA-GRAPH	FIGURE NO.	TABLE NO.

IN THIS SPACE, TELL WHAT IS WRONG AND WHAT SHOULD BE DONE ABOUT IT.

TEAR ALONG PERFORATED LINE

PRINTED NAME, GRADE OR TITLE AND TELEPHONE NUMBER

SIGN HERE

DA FORM 1 JUL 79 2028-2

PREVIOUS EDITIONS ARE OBSOLETE.

P.S.--IF YOUR OUTFIT WANTS TO KNOW ABOUT YOUR RECOMMENDATION MAKE A CARBON COPY OF THIS AND GIVE IT TO YOUR HEADQUARTERS.

